

## Real-Time Insight for Organic Chemists with FTIR Reaction Analysis

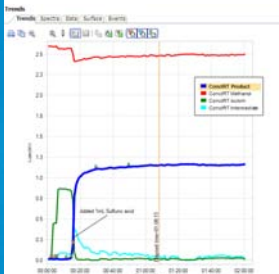

### A Total Reaction Analysis System

Specific reaction analysis functionality provides a quick and easy way to convert reaction data into chemical information. ConclRT™ LIVE automatically analyzes experiments in real time and Fit Referee Data functions allow users to quickly correlate offline data to iC IR™ trends.

### Sampling Technology

New silver halide (AgX) fiber optic technology with Comp™ and integrated temperature sensors make it easy to reliably monitor chemistry across a wide range of applications and scales - even at extremely small volumes of 1mL or less.

### Ergonomic

Designed specifically to require as little hood or benchspace as possible using the most current technology available, the lightweight and mobile system can be easily moved to where it's needed.

### iC IR™ Software

ReactIR™ iC10, coupled with powerful iC IR™ software, creates the perfect reaction analysis system that provides fast and effortless real-time reaction monitoring and understanding.



### ReactIR™ iC10

ReactIR™ iC10 is an FTIR based *in situ* reaction analysis system designed specifically for the organic chemist. Data rich information about reaction initiation, progression and endpoint determination reduces the time and number of experiments required to optimize reaction yield and purity. *In situ* data allows scientists to understand reaction mechanism and pathway facilitating a full comprehension of reactions difficult to characterize otherwise.

Technical data

## Real-Time Insight for the Organic Chemist with FTIR Reaction Analysis

### Size

ReactIR™ iC10 was designed to require as little hood or bench space as possible. It sets a new standard for compactness and ease of use.

### Versatility

Because of its optimized design, ReactIR™ iC10 fits easily in a fume hood. Coupled with a flexible FiberConduit™ and our patented Comp™ (Diamond or Silicon ATR) probe technology, interfacing to a wide range of reaction vessels couldn't be easier.

### Application Area

ReactIR™ iC10 is ideal for daily use in the modern synthetic organic chemistry lab. It provides orthogonal complementary information to offline analysis techniques such as HPLC, mass spectroscopy, and NMR.

### Utilities

- Purge:
  - Instrument grade air or nitrogen
  - Dewpoint: -50°C
  - 4.7 lpm (10scfh) flow rate

### Computer Specifications

- DELL or 100% compatible versions
- Operating System: Windows XP, SP2
- Processor: DuoCore 2.2GHz or higher
- RAM: 2GB or higher
- Interface: USB cable

### Sampling Technology Options

A wide range of sampling technologies are available including silver halide (AgX) FiberConduit™ probes, flow cells, gas cells and specialized probes for high pressure and temperature reactors.

For a complete listing please visit [www.mt.com/reactir](http://www.mt.com/reactir).

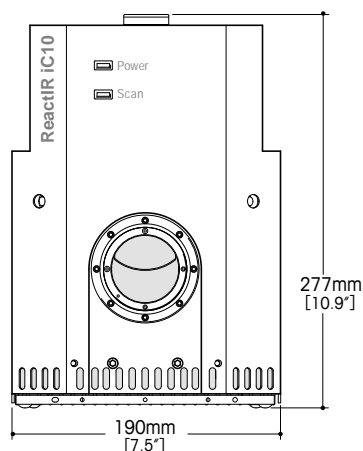

### System Specifications

- 216w x 356d x 280h (mm)
- Weight: 20kgs (45lbs)

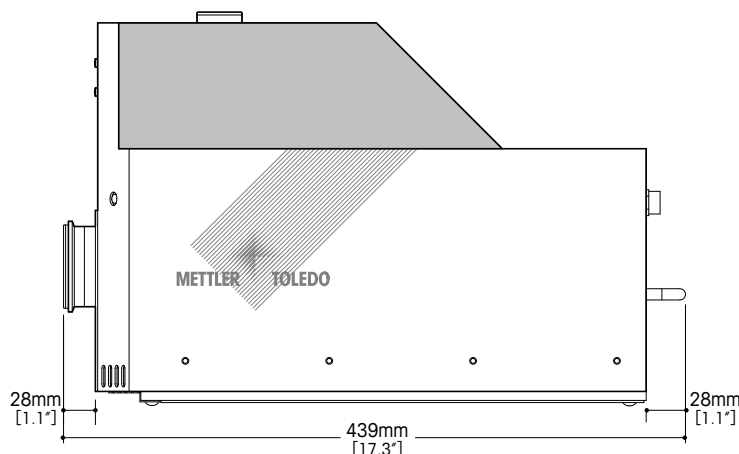

DS Series 9.5mm AgX Fiber Conduit™



DS Series Fiber-to-Sentinel™ (Fiber only – Sentinel™ purchased separately)



DS Series Fiber-to-Gas Cell (Fiber only – Gas Cell purchased separately)

	Fiber Length			Sensor		Probe Length			Temperature Range	Pressure Limit
	1.0m	1.5m	2.0m	DiComp™	SiComp™	216mm	305mm	457mm		
DS Series 9.5mm AgX Fiber Conduit™		✓	✓	✓	✓	✓	✓	✓	-80 – 180°C	69bar
DS Series 6.3mm AgX Fiber Conduit™		✓		✓	✓	✓			-80 – 180°C	69bar
DS Series Fiber-to-Sentinel™ (Fiber only – Sentinel™ purchased separately)	✓	✓		✓	✓				-80 – 300°C	345bar
DS Series Fiber-to-Gas Cell (Fiber only – Gas Cell purchased separately)	✓	✓							Ambient – 120°C	7bar



Internet: <http://www.mt.com/autochem>  
Worldwide service



Subject to technical changes 51725203  
©09/2009 Mettler-Toledo AutoChem, Inc.  
7075 Samuel Morse Drive  
Columbia, MD 21046 USA  
Telephone +1 410 910 8500  
Fax +1 410 910 8600  
Email [autochem@mt.com](mailto:autochem@mt.com)

[www.mt.com/ReactIR](http://www.mt.com/ReactIR)

For more information