

Characterize Your Chemistry with FTIR Reaction Analysis

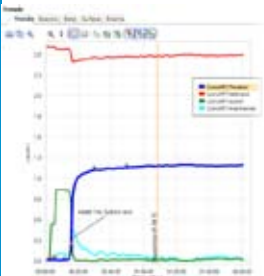

A Total Reaction Analysis System

Specific reaction analysis functionality provides a quick and easy way to convert reaction data into chemical information. ConclRT™ LIVE automatically analyzes experiments in real time and fit referee data functions to quickly correlate offline data to iC IR™ trends.

Sampling Technology

A wide range of probes and sensors, including the new, flexible, silver halide (AgX) fiber optic technology, means that virtually any reaction, under any condition, can be monitored.



Enhanced Performance

A dramatic reduction in instrument size and an increase in the number of features result in a reaction analysis tool that can handle a wide range of applications.



iC IR™ Software

ReactIR™ 45m coupled with powerful iC IR™ software creates the perfect reaction analysis system that provides fast and effortless reaction characterization and optimization.



ReactIR™ 45m

ReactIR™ 45m is an FTIR based, high performance, *in situ* reaction analysis system designed specifically for the chemist and chemical engineer who require the highest level of precision for kinetic studies and quantitative analysis. It provides real-time information on the effect of changing reaction conditions such as solvent, catalyst, temperature, and reagent addition rate, saving valuable resources. Based on the information provided by ReactIR™ 45m, scientists are able to correlate, in real time, the impact of varying reaction conditions to reaction performance - dramatically reducing development time.

Technical data

Characterize Your Chemistry with FTIR Reaction Analysis

Size

The ReactIR™ 45m provides an ergonomic and agile solution for in situ reaction analysis. Its reduced size greatly improves handling and requires minimal bench space – a 60% volume reduction in footprint and 50% weight reduction.

Versatility

The ReactIR™ 45m is designed to be used within a fume hood. Coupled to any of a wide range of probes and sensors, virtually all types of reactions, under any conditions can be successfully monitored. Having complete control of system alignment and “tuning” allows maximum performance of the system when using any of the available sampling technologies.

Application Area

The maximized performance and ultimate sampling technology flexibility makes the ReactIR™ 45m ideal for the process development chemist and chemical engineer who need to optimize and scale-up a wide range of chemistries.

Utilities

- Purge:
 - Instrument grade air or nitrogen
 - Dewpoint: -50°C
 - 4.7 lpm (10scfh) flow rate

Computer Specifications

- DELL or 100% compatible versions
- Operating System: Windows XP, SP2
- Processor: DuoCore 2.2GHz or higher
- RAM: 2GB or higher
- Interface: USB cable

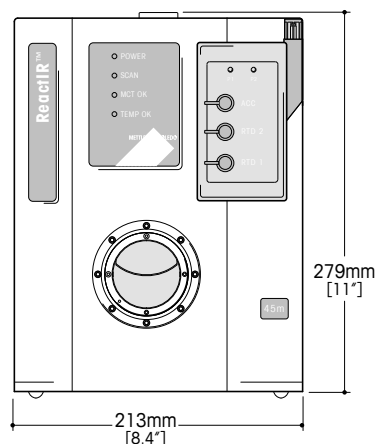



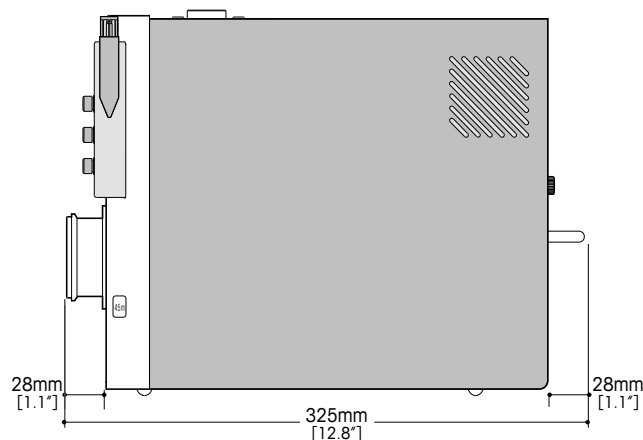

System Specifications

- 216w x 279d x 381h (mm)
- Weight: 16kgs (35lbs)



Sampling Technology Options

A wide range of sampling technologies are available including silver halide (AgX) FiberConduit™ probes, flow cells, gas cells and specialized probes for high pressure and temperature reactors. For a complete listing please visit www.mt.com/reactir.

	Fiber Length			Sensor		Probe Length			Temperature Range	Pressure Limit
	1.0m	1.5m	2.0m	DiComp™	SiComp™	216mm	305mm	457mm		
 DS Series 9.5mm AgX Fiber Conduit™		✓	✓	✓	✓	✓	✓	✓	-80 – 180°C	69bar
 DS Series 6.3mm AgX Fiber Conduit™		✓		✓	✓	✓			-80 – 180°C	69bar
 16mm Comp™ ATR K6 Conduit (K6 Conduit)		N/A		✓	✓	178mm, 299mm, 362mm			-80 – 200°C (300°C as special)	100bar (350bar as special)
 25.4mm Sentinel™ (K4 Conduit)		N/A		✓	✓	28.6mm (other lengths as special)			-80 – 200°C (300°C as special)	100bar (350bar as special)



Internet: <http://www.mt.com/autochem>
Worldwide service



Subject to technical changes 51725198
©09/2009 Mettler-Toledo AutoChem, Inc.
7075 Samuel Morse Drive
Columbia, MD 21046 USA
Telephone +1 410 910 8500
Fax +1 410 910 8600
Email autochem@mt.com

www.mt.com/ReactIR45m

For more information