



Table of Contents

1	Installation	3
1.1	Mechanical installation	3
1.1.1	Support Interface (Support Surface)	3
1.1.2	Weighing Interface (Weighing Platform)	3
1.2	Electrical Installation	5
1.2.1	Typical Configuration	5
1.2.2	Power Supply	6
1.2.3	Cables and Wiring	6
1.3	Pin Assignment of the M12 Connector	6
1.4	ConBlock Connection – Safe Area	7
2	Configuration	8
2.1	Communication Protocol	8
2.2	Checklist for Configuration	8
2.3	PC Configuration	9
3	Operation	10
3.1	Operation Limits	10
3.2	Applying / Removing the Weighing Object	10
3.3	Transmission of Weight Values	10
3.4	Tare Function	11
3.5	Reset (Zero) Function	11
4	Technical Data	12
4.1	General Data	12
4.2	Interface Specifications	13
4.3	Type Designation Code	14
4.4	Dimensions	15
4.5	Accessories	17
4.6	Customer Spare Parts	17

1 Installation

1.1 Mechanical installation

1.1.1 Support Interface (Support Surface)

Observe the following when designing the support interface for the weigh module:

- Wherever possible, provide a vibration-free support surface for the weigh module.
- Make sure that the weigh module is as perfectly horizontal as possible.
Note: It is acceptable to have a weigh module that is not perfectly horizontal if its position is not altered after it has been adjusted, e.g., if it is mounted in a fixed position in the system.
- Determine the floor properties in the location where the system is to be set up.
Make sure that no building oscillations are transferred to the support surface via the floor.
- The support surface has to be stiff because a stable mechanical base is mandatory for precise and fast weighing results.
- The support surface must be absolutely level to prevent the base plate from twisting.
- Take care that no vibrations are transmitted via the connecting cable.

Important: Avoid temperature influences over the support surface to the weigh module.

Mounting the weigh module on the support surface

- Use the 4 mounting holes (1) (\varnothing 5.5 mm) at the bottom plate to fasten the weigh module to the support surface.



1.1.2 Weighing Interface (Weighing Platform)

When building a custom weighing platform, the following needs to be considered in order to achieve the best weighing performance:

Material of the Weighing Platform

The material has to be selected from electrically conductive material in order to prevent the accumulation of electrostatic charges.

Weight and stiffness

Light and stiff weighing platforms are less susceptible to vibrations.

Preload

- The preload range of the weigh module is limited (see product specific datasheet for value).
- Custom weighing platforms which are built on the top of the adapter weighing pan will reduce the weighing range of the weigh module by their weight.

Eccentricity

A custom weighing platform has to be designed so that the center of gravity of the weighing platform lies at the primary loading axis or as close as possible.

The primary loading axis goes through the center point of the adapter weighing pan (1).

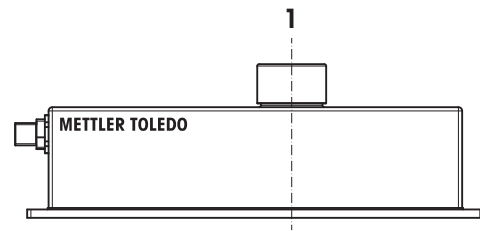

Overload protection limits

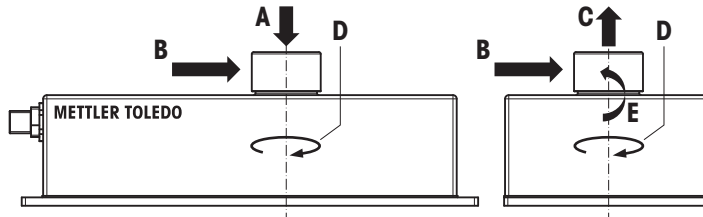

Please take care of the overload protection limits specified in the table below. The weigh module can be damaged if these limits are exceeded.

Weigh module	A Max. compression	B Max. lateral force	C Max. uplift force	D Max. rotating torque	E Max. lateral bending torque
WKC204	4 kg	5 N	15 N	1 Nm	2 Nm
WKC603	6 kg	5 N	20 N	1.3 Nm	3 Nm
WKC6002	20 kg	20 N	50 N	3 Nm	10 Nm

Mounting the weighing platform

- 1 Take off the adapter weighing pan (2) from the load receiver.
- 2 Use the M3 threaded mounting holes (3) to fasten the custom weighing platform onto the adapter weighing pan when there is no contact to the load receiver.
See [Dimensions ▶ Page 15].
- 3 Put the weighing interface consisting of custom weighing platform and adapter weighing pan on the load receiver (black plastic adapter).

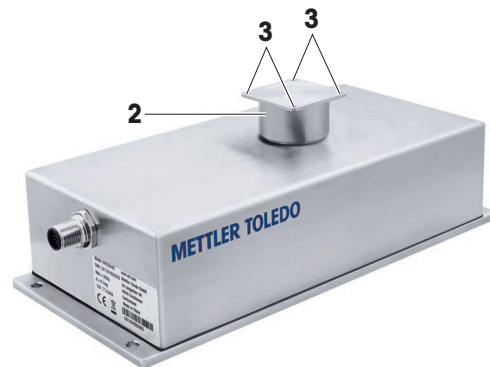

Important

Only mount the custom weighing pan to the adapter weighing pan when there is no contact to the load receiver. Otherwise the load cell can be damaged due to overload forces during installation.

1.2 Electrical Installation

1.2.1 Typical Configuration

WKC weighing modules can be connected to the control system via the standard M12 cable (12 pins). The terminal strip called "ConBlock" which is provided by METTLER TOLEDO as an accessory can be used to facilitate the wiring.

Automated network configuration

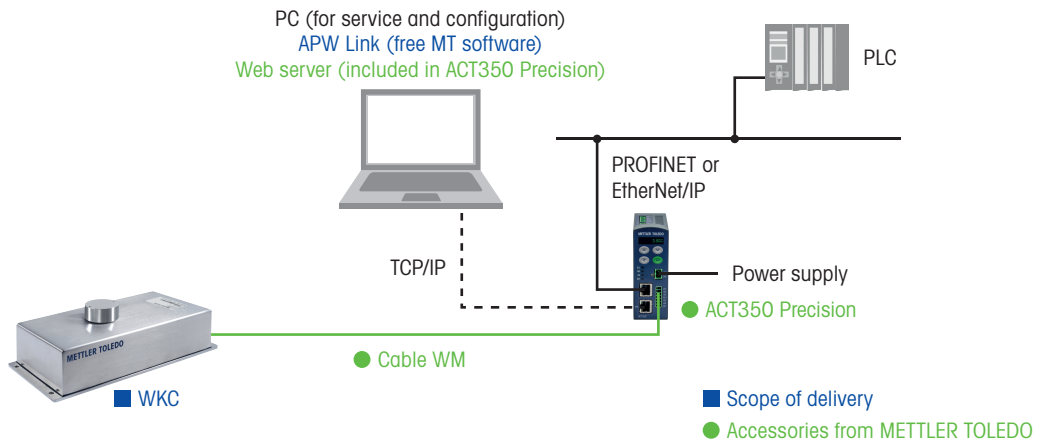

Serial interface configuration

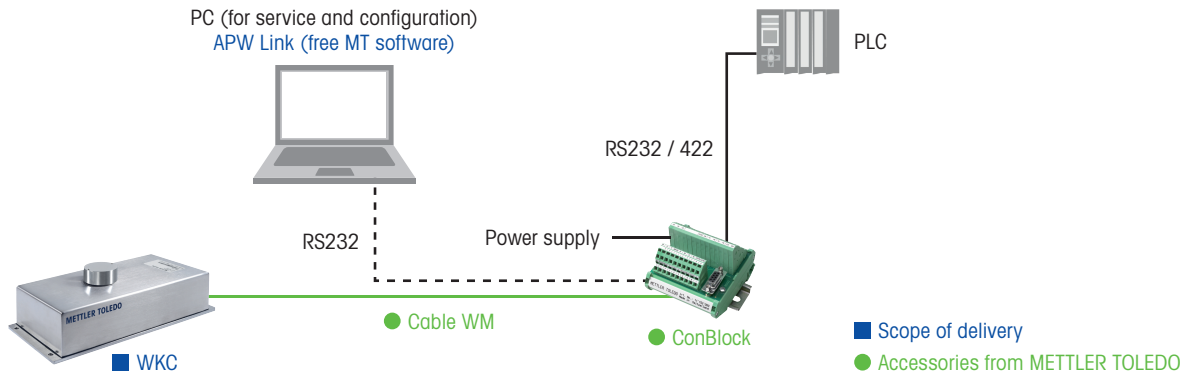

1.2.2 Power Supply







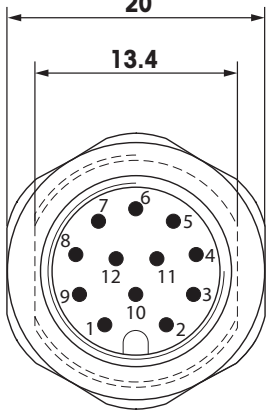

WKC weigh modules work with 12 to 24 V DC nominal (10 to 29 V DC), input current: max. 0.2 A

- 1 Use a stable power supply with no voltage fluctuations.
- 2 If voltage fluctuations cannot be prevented, use a voltage regulator to deliver a constant voltage value to the weigh module.
- 3 The power supply must be approved by the respective national test center of the country in which the weigh module will be used.

1.2.3 Cables and Wiring

- METTLER TOLEDO recommends using standard cables and advises against tailoring cables to extend the cable range. Electromagnetic behavior and the reliability of the data communication are only tested for standard cables. Therefore, no guarantee can be given for longer tailor-made cables.
- However, if it is inevitable to build a tailor-made cable, a shielded cable must be used to prevent faults in the data transmission and/or weighing results. The shield must be connected to the connector housing on one side and to the system ground on the other side to avoid ground loops. The best grounding scheme may only be determined by trial and error on site.
- It is important to observe the maximum allowable cable length of the physical transmission medium. Long transmission cables should be isolated against electro-magnetic interference by using shielded cables and twisted pairs. Data cables should be separated and isolated from power lines.
- Wiring must be correct before powering up the load cell. Confusing the power pins with data pins might damage the load cell. Wires should not be plugged in or unplugged while power is applied to the load cell.

1.3 Pin Assignment of the M12 Connector

Connector M12	Pin	Signal	Cable color *	
P1 	1	Power (12 to 24 V DC)	White	
	2	GND (Ground)	Brown	
	3	RS422 GND (Ground)	Green	
	4	TXD (RS232)	Yellow	
	5	RTS (RS232)	Gray	
	6	RXD (RS232)	Pink	
	7	CTS (RS232)	Blue	
	8	GND (RS232)	Red	
	9	TX+ (RS422) / B+ (RS485)	Orange	
	10	TX- (RS422) / A- (RS485)	Purple	
	11	RX+ (RS422) / B+ (RS485)	Black	
	12	RX- (RS422) / A- (RS485)	Violet	
	Shield		Braid	

* Cable color of the METTLER TOLEDO standard cables.

RS422 / RS485 configuration

The RS422 interface is directly available via the connection terminals. For the RS485 configuration, the following signals must be connected:

A-: Tx- and Rx-

B+: Tx+ and Rx+

1.4 ConBlock Connection – Safe Area

ConBlock provides the following terminals:

- System connection side: 10 terminals
- Weighing platform connection side: 2 x 10 terminals
- RS232 interface (DSub 9) for configuration and servicing

ConBlock connections – weighing platform side

The WKC weigh module is delivered with a 12 wire open end cable. The corresponding terminals of the ConBlock are identified by the wire color and the respective pin designation:

Pin	J	D	H	T	F	K	G	E	A	O
Color	–	–	–	–	–	–	–	–	White	Brown and green
Signal	–	–	–	–	–	–	–	–	V DC	GND

Pin	L	U	P	C	R	B	S	N	M	Shield
Color	Orange	Black	Purple	Violet	Blue	Red	Grey	Pink	Yellow	Braid
Signal	TX+	RX+	TX–	RX–	CTS	GND INT	RTS	RXD	TXD	Shield

ConBlock connections – system side

The connection terminal strip is grouped according to the following functions: RS232 and RS422/RS485 interfaces, input voltages and digital inputs and outputs

RS232		RS422 (in)		RS422 (through)		Power	–	–	–
RXD	RTS	RX+	TX+	RX+	TX+	V DC	–	–	–
TXD	CTS	RX–	TX–	RX–	TX–	GND	–	–	–
GND INT	Shield	Shield		Shield		PE	–	–	–

2 Configuration

2.1 Communication Protocol

WKC weigh modules make use of the MT-SICS communication protocol in order to communicate with control systems. The MT-SICS protocol is defined by METTLER TOLEDO.

- MT-SICS stands for **M**ETTLER **T**OLEDO **S**tandard **I**nterface **C**ommand **S**et.
- MT-SICS is an ASCII-based communication protocol with string-type data format.
- Each string includes 8 data bits representing the letter or digit, and one stop bit.

For more information refer to the Reference Manual for MT-SICS Interface Commands, 11781363 (English). This can be downloaded from

Documentation WKC

► <https://www.mt.com/ind-wkc-documents>

2.2 Checklist for Configuration

Before configuring the weigh module, clarify the following points:

- What sort of weighing process is involved (control weighing or filling to a target weight)?
- What level of precision must be achieved (expressed in grams)?
- What level of repeatability is required (expressed in grams)?
- What weighing rate is required?
- How heavy is the load supporting device (preload)?
- Which external weight will be used for checking/adjustment?
- What sort of interference might be present in the environment (vibrations, air draft, electrostatics)?
- How will the weighing object be applied?
- To which PLC interface will your system be connected?

2.3 PC Configuration

WKC weigh modules can be configured with MT-SICS commands. For this configuration, the weigh module must be connected to a PC or laptop.

In order to configure parameters of the weigh module by a PC or laptop, the following items are needed:

Hardware requirements

- WKC weigh module
- M12 connection cable
- RS232 cable with USB converter (if needed)
- PC or laptop with Windows operating system

Software requirements: APW-Link™

- APW-Link™ software version V2.3 or higher, to configure the weigh module with MT-SICS commands

The APW-Link™ can be downloaded from the following link:

Download link

► <http://www.mt.com/apw-link>

Following aspects of the weigh module and many more parameters can be configured with APW-Link™:

- Stability criteria (USTB command)
- Filter properties (M01 command)
- Filter damping (M02 and FCUT commands)
- External and internal adjustment and test (C2, TST2, C3, TST3, C7, C8 commands)
- Update rate for continuous weight transmission (UPD command)

For more information refer to the Reference Manual for MT-SICS Interface Commands, 11781363 (English).

This can be downloaded from

Documentation WKC

► <https://www.mt.com/ind-wkc-documents>

3 Operation

3.1 Operation Limits

When operating WKC weigh modules, the following operation limits have to be observed:

- The maximum permissible load on the weigh module is defined by the maximum capacity specification of the weigh module (see data sheet). This range includes the custom weighing platform (preload) plus the weighed object and the container.
- For environmental conditions see data sheet. The specified metrological performance of the weigh module is ensured for the compensated temperature range (10 ... 30 °C).

3.2 Applying / Removing the Weighing Object

When applying or removing the weighing object on / from the weighing platform, observe the following important rules:

- Excessive additional forces or vibrations affecting the weighing platform as a result of applying or removing the weighing object can impair the weighing duration and the result.
- Make sure that you keep additional forces and vibrations to a minimum when applying or removing the weighing object. Lateral impacts should be avoided.
- The weighing object should come to rest on the weighing platform as quickly as possible once it has been applied. If the weighing object is pushed sideways onto the weighing platform by a feed mechanism, a certain height difference between the weighing platform and the loading/unloading arm should be ensured. The weighing pan should be lower than the loading level and higher than the unloading level.
- Make sure that the object or its center of gravity is as close to the center of the weighing platform as possible during weighing or that it is always applied in the same way.
- It is not recommended to move the weigh module toward the weighing object. This kind of setups can cause shock overloads inside the weigh module due to the dynamic movement in a short time. Shock overloads are always difficult for the weigh module to handle and might lead to failure over the long term.

3.3 Transmission of Weight Values

The weight values that are transmitted relate either to the zero point or to the point derived from the tare command, depending on whether the previous function executed was a reset to zero or taring.

Commands that are normally only completed when a stability criterion is met respond with an abort if the stability has not been achieved within the defined time limit (Timeout, command M67).

The following MT-SICS commands can be used to request weight results from the weigh module:

MT-SICS command	Descripton
S	Transmit stable weight value
SI	Transmit weight value immediately (stable, not stable)
SIR	Transmit weight value immediately and repeat (stable, not stable)
SNR	Transmit next stable weight value and repeat
SR	Transmit weight value and repeat when the weight changes

For more information refer to the Reference Manual for MT-SICS Interface Commands, 11781363 (English). This can be downloaded from

Documentation WKC

[▶ https://www.mt.com/ind-wkc-documents](https://www.mt.com/ind-wkc-documents)

3.4 Tare Function

In taring the weight value that relates to the current zero point is regarded as the tare weight and is transferred to the tare memory. At the same time, the current displayed weight value is reset to zero.

The following MT-SICS commands can be used to execute the tare function:

MT-SICS command	Descripton
T	Adopt current stable weight value as tare weight
TA	Set / query tare weight
TAC	Delete tare weight
TI	Adopt weight value as tare weight immediately

Note

The taring functions cannot be executed if the current weight value is negative relative to the current zero point. For more information refer to the Reference Manual for MT-SICS Interface Commands, 11781363 (English). This can be downloaded from

Documentation WKC

[▶ https://www.mt.com/ind-wkc-documents](https://www.mt.com/ind-wkc-documents)

3.5 Reset (Zero) Function

The reset function defines a new zero point (reference point), the current weight value is reset to zero and the tare memory is cleared. Depending on the configuration, the reset is performed automatically whenever the module is switched on or the stored value is used.

The following MT-SICS commands can be used to execute the reset (zero) function:

MT-SICS command	Descripton
Z	Adopt current stable weight value as zero point
ZI	Adopt the current weight value as the zero point immediately

Note

For more information refer to the Reference Manual for MT-SICS Interface Commands, 11781363 (English). This can be downloaded from

Documentation WKC

[▶ https://www.mt.com/ind-wkc-documents](https://www.mt.com/ind-wkc-documents)

4 Technical Data

4.1 General Data

Dimensions	
Weigh module (L x W x H)	245 x 112 x 90.5 (WKC6002C) 245 x 112 x 82 (WKC204C / WKC603C)
Interfaces	
Interface type	RS422, bidirectional, full duplex, 2'400 to 38'400 bps RS485, unidirectional, half duplex, 2'400 to 38'400 bps RS232C, bidirectional, full duplex, 2'400 to 38'400 bps
Interface update rate	max. 92 Hz
Connector	M12, 12 pin, male, A-coded
Power supply	
Power supply voltage	12 to 24 V DC nominal (10 to 29 V DC)
Input current	max. 0.2 A
Materials	
Housing, base plate	Stainless steel (EN 1.4307 / 304)
Weighing pan	Stainless steel (EN 1.4307 / 304)
Seal between baseplate and housing	NBR 60° Shore A, black, 1000 Ohms
Surface roughness of housing	N7 (Ra1.6) or better
Ambient conditions	
Operating temperature	+10 to +30 °C
Allowable ambient temperature	+5 to +40 °C
Storage temperature	-25 to +70 °C
Relative humidity	Max. 80 % at 31 °C, decreasing linearly to 50 % at 40 °C, non-condensing
Max. height above sea level	4,000 m (13,330 ft)
Warm-up time	At least 30 minutes after power up
IP protection (in operational state with weighing platform in place)	
When weighing	IP42

4.2 Interface Specifications

For the pin assignment see [Pin Assignment of the M12 Connector ▶ Page 6].

RS422/RS485 interface

Parameter	RS422/RS485
Interface type	Voltage-controlled interface in accordance with EIA RS422 and EIA RS485 standards (CCITT V.11, DIN 66259 Part 3))
Max. cable length	1200 m
Signal level	Outputs: ± 6 V Inputs: ± 3 V
Type of operation	RS422: full duplex RS485: half duplex
Type of transmission	bit serial, asynchronous
Transmission code	ASCII
Baud rates	2'400 to 38'400
Bits/parity	7 Bit/Even, 7 Bit/Odd, 7 Bit/None, 8 Bit/None
Stop bits	1 stop bit
Handshake	Non, XON/XOFF, RTS/CTS
Line break	<CR><LF>

RS232 interface (service interface)

Parameter	RS232C	
Interface type	Voltage-controlled interface in accordance with EIA RS-232C / DIN 66020 standard(CCITT V.24/V.28)	
Max. cable length	15 m	
Signal level	Outputs +5 V ... +15 V ($R_L = 3 \dots 7$ kOhms) -5 V ... -15 V ($R_L = 3 \dots 7$ kOhms)	Inputs +3 V ... 25 V -3 V ... 25 V
Type of operation	full duplex	
Type of transmission	bit serial, asynchronous	
Transmission code	ASCII	
Baud rates	2'400 to 38'400	
Bits/parity	7 Bit/Even, 7 Bit/Odd, 7 Bit/None, 8 Bit/None	
Stop bits	1 stop bit	
Handshake	Non, XON/XOFF, RTS/CTS	
Line break	<CR><LF>	

4.3 Type Designation Code

Your weigh module is uniquely identified by the type designation. The type designation can be found on the laser label on your weigh module.

WKC **C**
1 2

#	Designation	Values
W	Weigh	–
K	Kit	–
C	Compact	–
1	Capacity and readability	<ul style="list-style-type: none"> • 204: 220 g / 0.1 mg • 603: 620 g / 1 mg • 6002: 6200 g / 10 mg
2	Internal adjustment feature	C

4.4 Dimensions

WKC204C and WKC603C

Round weighing pan

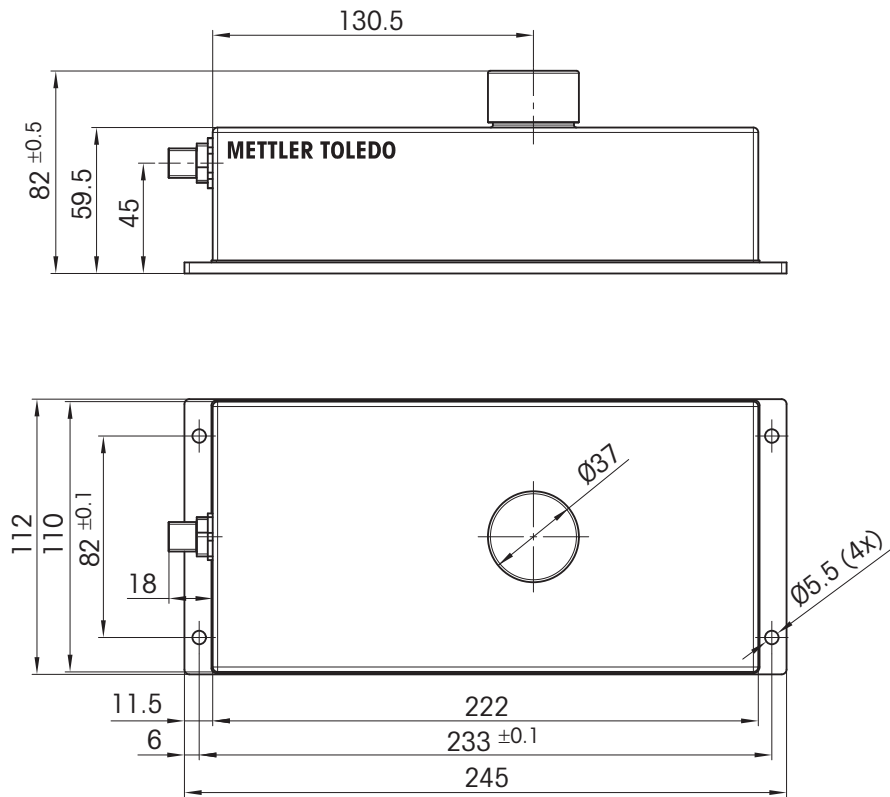

Square weighing pan

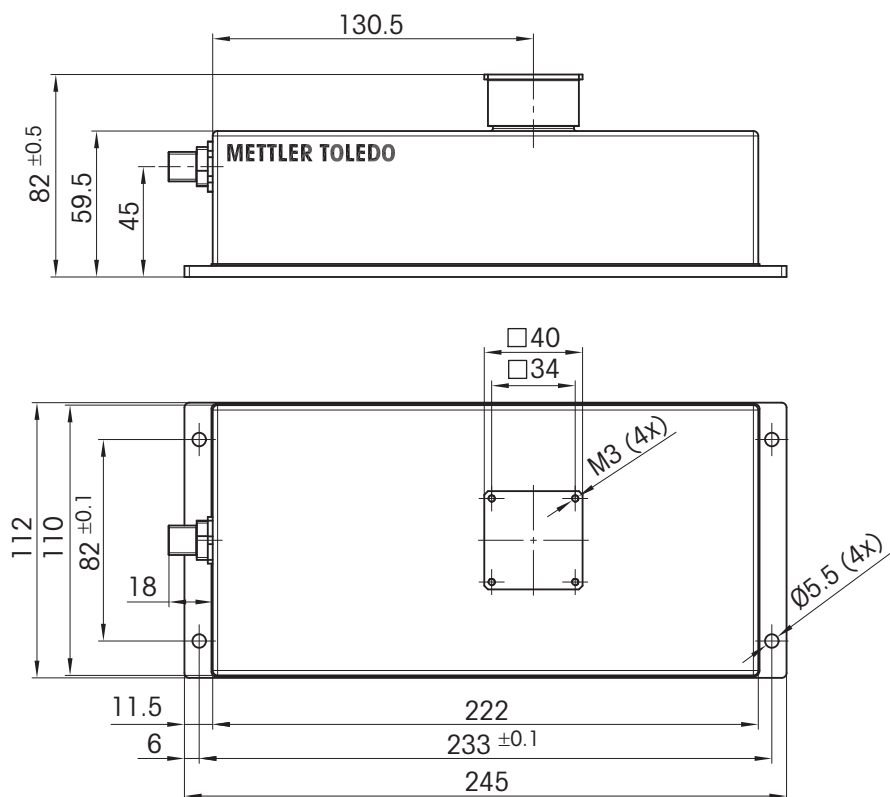

WKC6002C

Round weighing pan

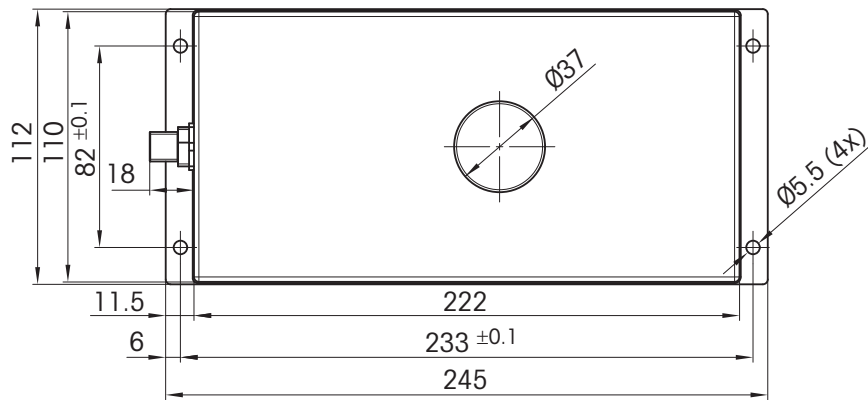
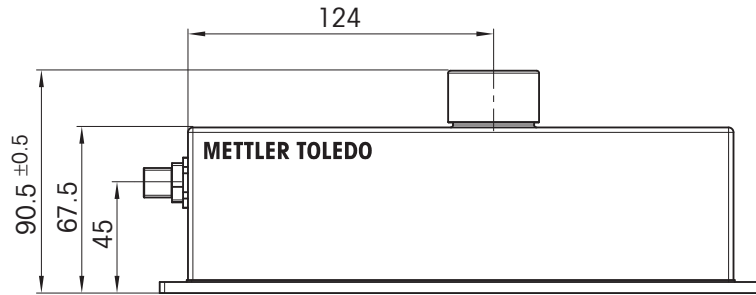

Square weighing pan

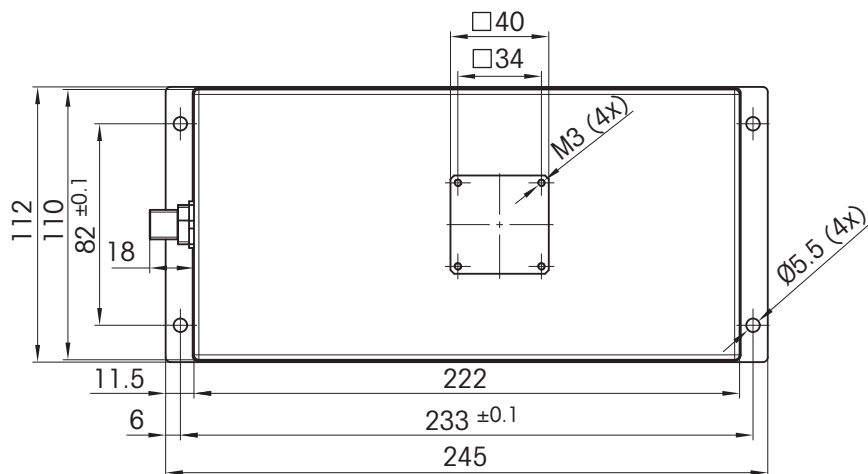
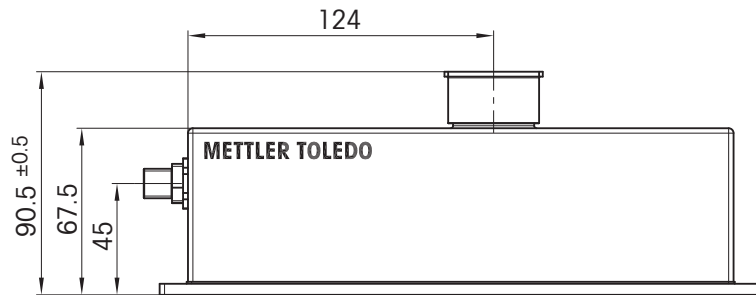

4.5 Accessories

For accessories see the respective product datasheet. (www.mt.com/ind-wkc-documents)

Documentation WKC

► <https://www.mt.com/ind-wkc-documents>

4.6 Customer Spare Parts

Item	Description	Order number
Spare Packaging WKC204, WKC603, WKC6002	Cardboard box, foam inlay	304 594 77

To protect your product's future:

METTLER TOLEDO Service assures the quality, measuring accuracy and preservation of value of this product for years to come.

Please request full details about our attractive terms of service.

► www.mt.com/service

www.mt.com

For more information

Mettler-Toledo GmbH

Industrial
8606 Nänikon, Switzerland
www.mt.com

Subject to technical changes.
© 12/2020 METTLER TOLEDO. All rights reserved.
30297212E en



30297212