

# Operating instructions

**METTLER TOLEDO**

**Differential weighing**

**Application software for PR/SR balances**

**METTLER TOLEDO**

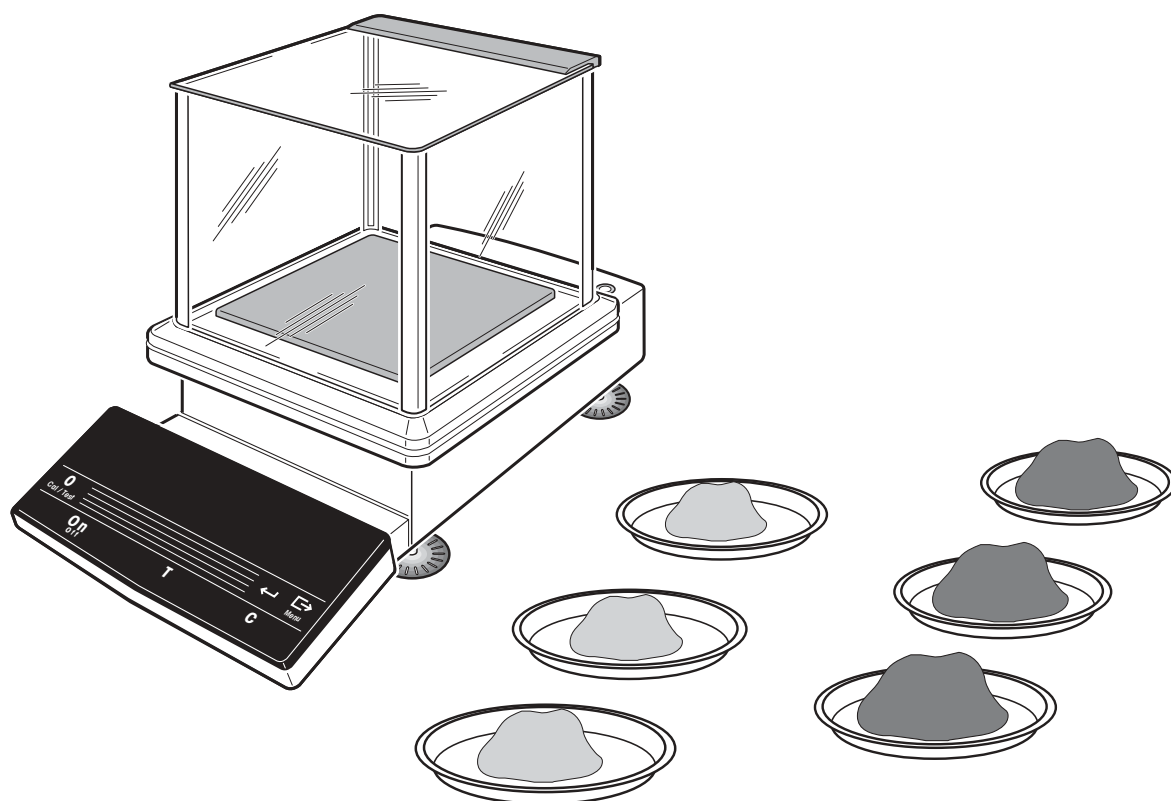



<b>Contents</b>	<b>Page</b>
<b>1 Introduction .....</b>	<b>2</b>
1.1 The Differential weighing application software for PR/SR balances .....	2
1.2 Standard equipment .....	3
<b>2 Installing the application software cassette .....</b>	<b>4</b>
<b>3 Differential weighing .....</b>	<b>5</b>
3.1 Determining the initial weight (weighing in) .....	7
3.2 Determining the back weight and difference .....	15
3.3 Deleting a series .....	17
3.4 Exiting differential weighing / Switching to weighing .....	17
<b>4 Additional functions .....</b>	<b>18</b>
4.1 Setting the weight transfer and printout .....	18
4.2 Recalling results and printing out – "Info" .....	20
4.3 Working with identification names .....	22
4.4 Working with the LC-BCR bar-code reader .....	23
4.5 Arbitrary order of the samples .....	24
4.6 Marking imperfect samples .....	25
<b>5 The menu .....</b>	<b>26</b>
<b>6 Communication with the computer, technical data .....</b>	<b>30</b>
6.1 Transferring the weighing results via the LocalCAN universal interface .....	30
6.2 Technical data .....	31
<b>7 Messages in the display .....</b>	<b>32</b>

## 1 Introduction

### 1.1 The Differential weighing application software for PR/SR balances

By replacing the standard R software cassette by the Differential weighing application software, you can use your PR or SR balance to determine the weight difference of your samples in a simple and dependable manner.

Naturally, with this application you also have the versatile and convenient functions of the PR/SR balances available, e.g. the fully automatic adjustment (FACT) or recording of the weighing results conforming to ISO/GLP.

Moreover, you can also use the balance for simple weighing.

These instructions describe the work with the Differential weighing application software for PR/SR balances. All settings not specifically applicable to this application and which you can undertake in the menu are described in the operating instructions of the PR/SR balances (section 6.2 and after).

#### The principle of differential weighing

In differential weighing one or more samples are investigated for weight changes.

The first workstep comprises determination of the sample container (tare, if used) and the initial weight of the sample (weighing in). The sample is then subjected to a process such as drying, centrifuging, filtering, ashing, vaporization, coating, etc. Following such treatment, the sample is reweighed (back weighing). The determined weight is used as a basis for calculation of the result, which is normally shown as a difference value in percent of the initial weight.

#### The advantages of the Differential weighing application software

Compared with simple weighing and evaluation of the results with a pocket calculator, the Differential weighing application software for PR/SR balances offers clear benefits:

- Fail-safe storage of data of up to 99 samples, recallable at any time.
- The samples can be divided between 9 series any way you like. This allows up to 9 groups of samples to be investigated independently of one another.
- Faultless calculation of the results.
- All data relevant to ISO/GLP are stored for each sample:
  - weight value of tare (container), initial weight and back weight
  - date and/or time of the initial weighing
  - date and/or time of the back weighing
  - automatic numbering within the series (starting at 01)
  - alphanumeric identification (if entered)
  - with repeated back weighing: number of repetitions

- The following data are stored for each series:
  - number of samples in the series
  - automatic series number (starting at 1)
  - alphanumeric identification (if entered)
- Convenient user guidance, while you are working with a series the prompt for the next step appears in clear text in the bottom line of the display, e.g. "->Load\_Sample".

### With the METTLER DeltaTrac you always have an overview



Series 1

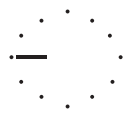

Series 9

When identifications are entered and information is called up, the METTLER DeltaTrac switches to a display of the current series number.

## 1.2 Standard equipment

The Differential weighing application software is also available in a set with the LC-BCR bar-code reader.

→ Check the standard equipment for completeness.

### Differential weighing application software

- Application software cassette
- Operating instructions
- Bar-code reader incl. operating instructions (only with set with order No. 225758)

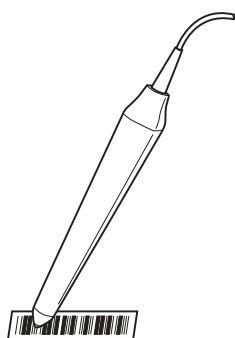

## 2 Installing the application software cassette

### Cautionary note



Before changing the application cassette, disconnect the balance from the power supply.

### Caution

When the application cassette is changed, the settings of the date, time, balance identification and password for the menu protection are lost.

When the balance is put into operation again with the new cassette, these settings must be reentered in the menu and saved (see operating instructions of the balance, section 6).

→ Before changing the application cassette, if applicable print out the settings on the attached printer with the "PrintOut" function under "Settings" (section 6.4.1 of the operating instructions for the PR/SR balances) and/or enter in the column "Your settings" in section 8.2.1 of the operating instructions for the PR/SR balances.

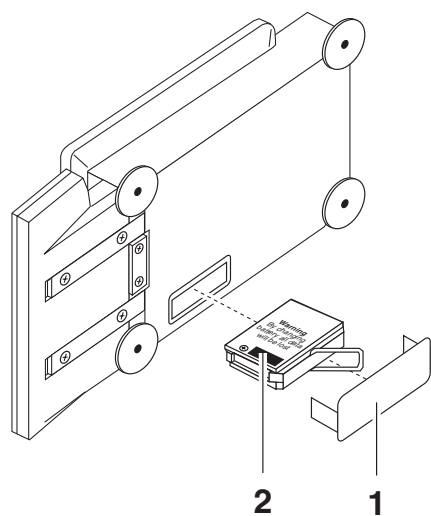

### PR balances

- Remove weighing pan and, if used, draft shield or draft shield element and weighing pan support and tilt the balance onto its left side.
- Remove cover (1).
- Hold standard program cassette (2) by its clip and pull out.
- Insert Differential weighing application cassette, replace cover.
- Move balance back to normal position, mount weighing pan support, draft shield or draft shield element and weighing pan.
- Level balance, see section 2.3 of the operating instructions for PR/SR balances.

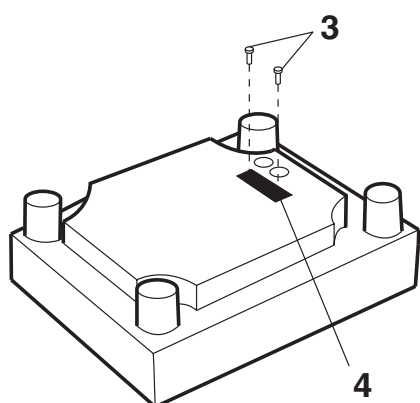

### SR balances

- Turn balance with weighing pan upside down.
- Unscrew screws (3) and remove cover (4).
- Hold standard program cassette (2) by its clip and pull out.
- Insert Differential weighing application cassette, screw on cover with seal to inside of balance.
- Move balance back to weighing position and level, see section 2.3 of the operating instructions for PR/SR balances.

### 3 Differential weighing

When defining a new series, you can select between 3 different ways of working for determining the initial weight of each sample.

#### Determining tare and initial weight in one workstep, see section 3.1.1

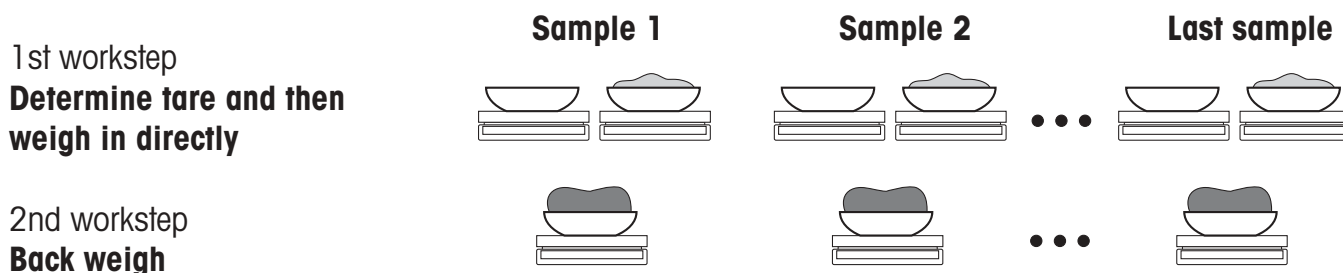

#### Determining all tare weights and then all initial weights in two different worksteps, see section 3.1.2

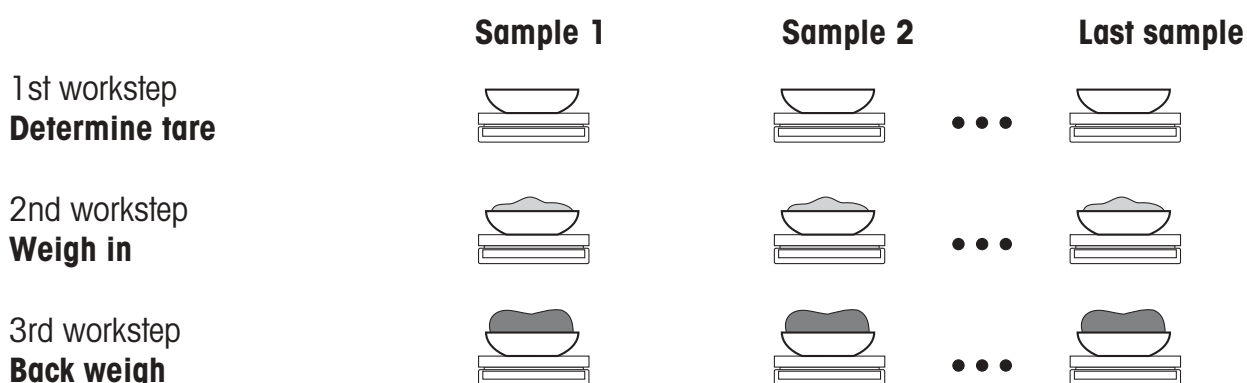

#### Determining the initial weight without tare, see section 3.1.3

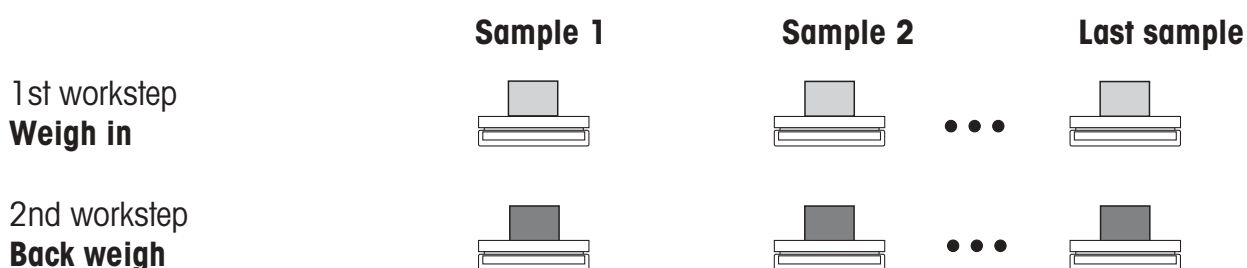

### Additive determination of the weight values

You can also determine your weight values without removing samples from the balance which have already been weighed.

For this, press the zeroing key  $\rightarrow 0 \leftarrow$  when the prompt " $\rightarrow$ Unload" appears.

With certified balances, additive determination is possible only up to  $\pm 2\%$  of the maximum capacity.

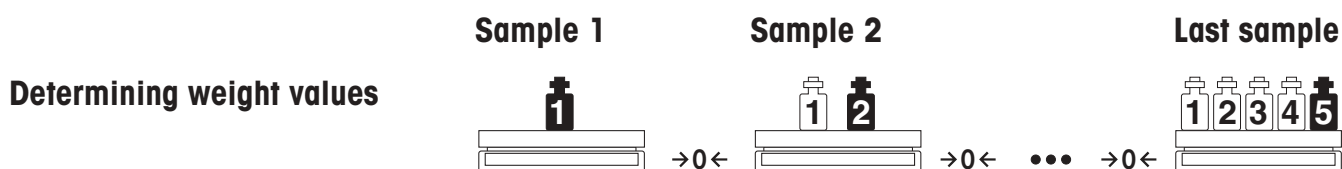

Irrespective of the way you choose to work, the Differential weighing application software for PR/SR balances offers you the additional possibilities and functions (e.g. automatic weight transfer) described in section 4.

### Requirement

"DiffWeigh" must be selected under "APPL" in the menu (factory setting, see section 5). The word "DiffW" then appears in the bottom line in simple weighing. Press the SmartBar under this word to activate the application.

In differential weighing you have the following functions and information available in the bottom line of the display:

	"New"	Definition of a new series, selection of the method
	"Processing"	Processing of an existing series
	"Delete"	Deletion of all data of the selected series
	"Info"	Recall and printing out of all sample data of a series
	"Exit"	Return to simple weighing

The top line shows the number of free sample locations "Free:xx".



### 3.1 Determining the initial weight (weighing in)

#### 3.1.1 Determining the tare and initial weight of all samples directly in succession

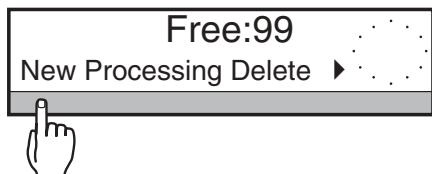

→ Press SmartBar under "New".  
The next free series number is shown in the top line and with the METTLER DeltaTrac.



→ Press SmartBar under "Tare&Sample".  
The display of the top line switches to the weight display, the bottom line shows the series No., sample No. and a text as user guidance which shows you the next step, e.g. "->Load\_Tare".

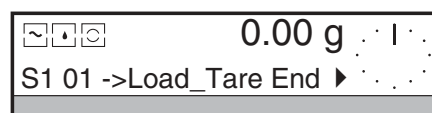

→ Load tare container for the first sample, the prompt "Save\_TareWt" then appears.

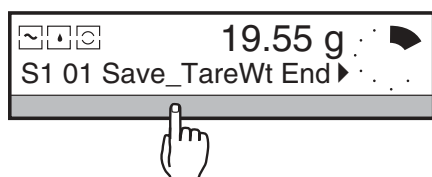

→ Press SmartBar under "Save\_TareWt".

•  
•  
•

→ Perform further steps as described in the user guidance until the step "->Unload".

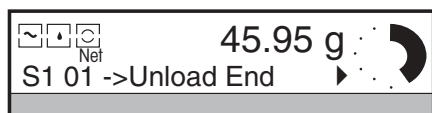

→ Remove sample from the balance.  
The balance is then set to zero, the sample number is incremented by 1 and the prompt "->Load\_Tare" reappears.

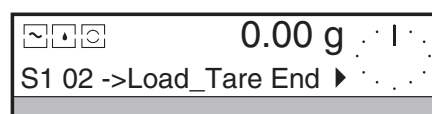

→ Load next tare container etc.

•  
•  
•

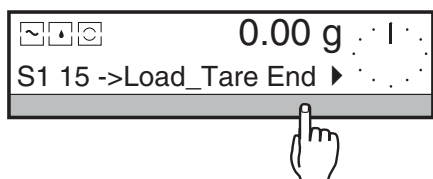

When all tare weights and initial weights of the series have been determined:

→ Press SmartBar under "End".  
The top line shows the inquiry "close S1?" (S1 = series 1).

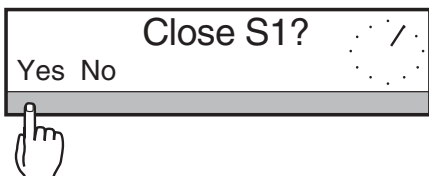

→ With "Yes" you close the first series and switch to simple weighing.  
With "No" you return to the last display under "Tare&Sample".

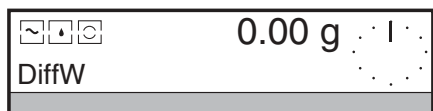

```

- DIFFERENTIAL WEIGHING -
17.01.96          08:42:10
Type:             PR5002
SNR:              1113000631
Bal:              QA lab M23
----- TARE+SAMPLE -----
Series Number      1

1      NI      102.43 g
2      NI      101.20 g
3      NI      102.52 g

Signature:
.....
----- END -----
    
```

**Printout**

In the factory setting, each weight value is automatically printed out with a sample number and marked as a net initial weight (NI). If you set the header printout in the menu (see section 6.4 of the operating instructions for the PR/SR balances), you can print out additional information, e.g. the balance identification.

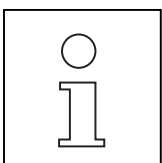

- If you do not have sufficient free storage space available for the new series or have already defined 9 series, the message "Memory full" appears. In such a case, first delete a completed series, see section 3.3.
- The series identification (LotID) is always available in differential weighing, irrespective of the settings in the menu.

- If you provide your series and samples with identification names (see section 4.3), you can later call up the series or sample directly using its name.

This is especially easy if the identification names are in the form of bar codes and you can use the LC-BCR bar-code reader.

- Weight values can also be determined automatically, see section 4.1.1.

### 3.1.2 Determining tare and initial weight in two separate worksteps

In the first workstep you determine the tare weight and, if required, the identification names of every single sample in the entire series.

In a second step you weigh in the samples for this series. You can proceed in any order or first weigh in only part of the series and complete it at a later time. Between these two steps you can use the balance for simple weighing.

#### 1st step: Determining tare

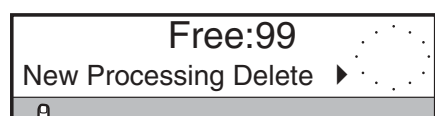

→ Press SmartBar under "New".  
The next free series number is shown in the top line of the display and with the METTLER DeltaTrac.



→ Press SmartBar under "Tare".  
The display of the top line switches to the weight display, the bottom line shows series No., sample No. and a text for user guidance which shows you the next step, e.g. "->Load\_Tare".

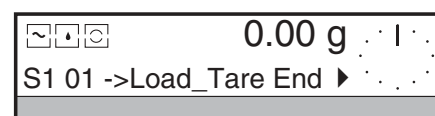

→ Load tare container for the first sample, the prompt "Save\_TareWt" then appears.

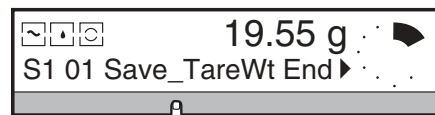

→ Press SmartBar under "Save\_TareWt", the next prompt "->UnloadTare" then appears.

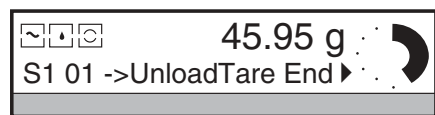

→ Remove tare vessel from the balance.  
The balance is then set to zero, the sample number is incremented by 1 and the prompt "->Load\_Tare" reappears.

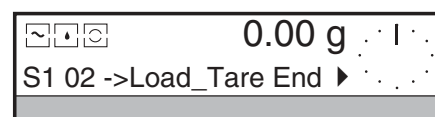

→ Load next tare container etc.

•  
•  
•

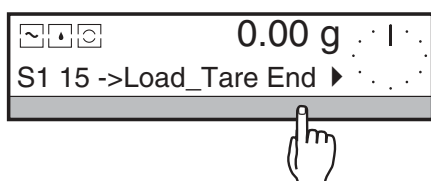

When all tare weights of the series have been determined:

- Press SmartBar under "End".  
The top line shows the inquiry "Close S1?" (S1 = series 1).

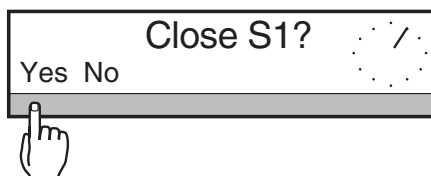

- With "Yes" you close the first series and switch to simple weighing.  
With "No" you return to the last display under "Tare".

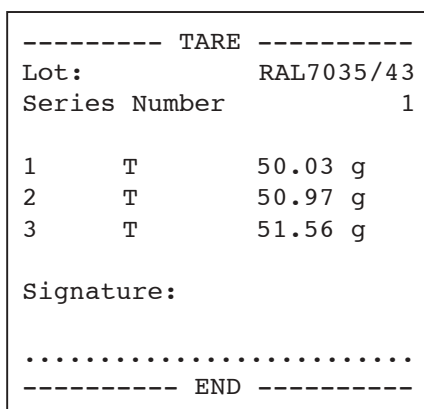
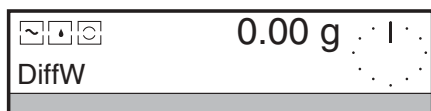

**Printout**

In the factory setting the tare weights are not printed out. However, you can include tare values in the record under "Printout" (see section 4.1.2).

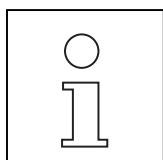

- If you do not have sufficient free storage space available for the new series or have already defined 9 series, the message "Memory full" appears. In such a case, first delete a completed series, see section 3.3.
- The series identification (LotID) is always available in differential weighing, irrespective of the settings in the menu.
- If you provide your series and samples with identification names (see section 4.3), you can later call up the series or sample directly using its name.  
This is especially easy if the identification names are in the form of bar codes and you can use the LC-BCR bar-code reader.
- Weight values can also be determined automatically, see section 4.1.1.

## 2nd step: Determining initial weight

In the second workstep the initial sample weights are determined.

Here, not all samples for which tare weights were determined in the first step must be weighed in. Further, the individual samples can be weighed in and determined in any order, see section 4.4.

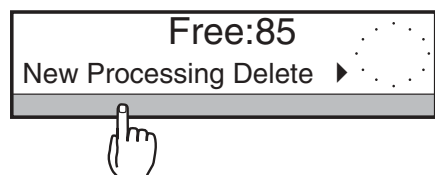

→ Press SmartBar under "Processing".

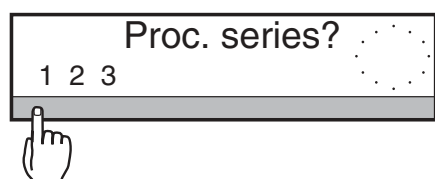

→ Select the desired series with the SmartBar.

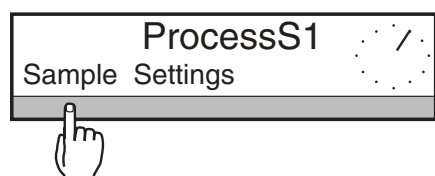

→ Press SmartBar under "Sample".  
The display of the top line switches to the weight display, the bottom line shows series No., sample No. and a text for user guidance which shows you the next step, e.g. "→Weigh-in".

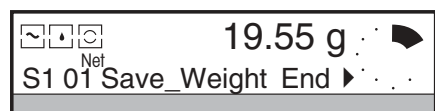
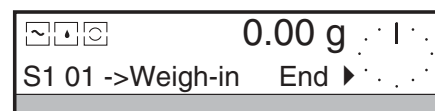

→ Load tare container for the first sample, weigh-in, than the prompt "Save\_Weight" appears.



→ Perform the further steps in accordance with the user guidance until the step "Unload".

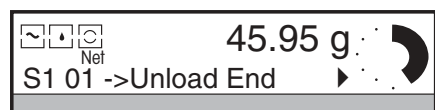

→ Remove sample from the balance.  
The balance is then set to zero, the sample number is incremented by 1 and the prompt "→Weigh-in" reappears.

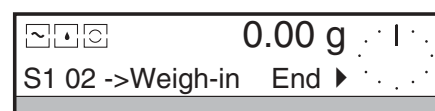

→ Load next tare container etc.



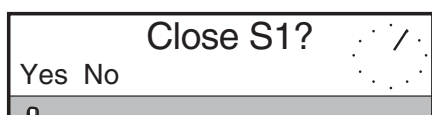

After the last sample for which a tare weight has been determined has been weighed in, the message "Last sample" appears briefly and then the inquiry "Close S1?" (S1 = series 1).

→ With "Yes" you close the first series and switch to simple weighing.

With "No" you return to the last display under "Sample".

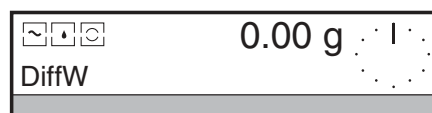

If you do not wish to weigh in several samples until later, press SmartBar under "End" to close the weighing in of the series prematurely.

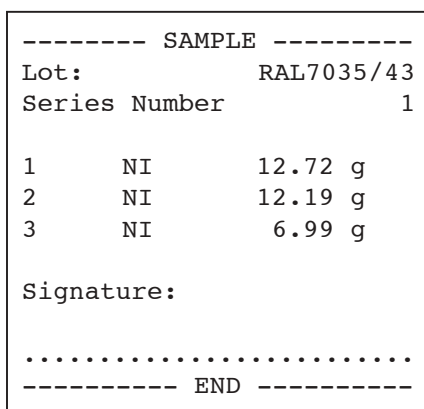

### Printout

In the factory setting, every weight value is automatically printed out with sample number and marked as a net initial weight (NI).

If you set the header printout in the menu (see section 6.4 of the operating instructions for the PR/SR balances), you can print out additional information, e.g. the balance identification.

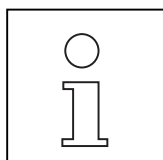

- The samples can also be weighed in any order, see section 4.5.
- If you have determined the tare weights with identification names, you can also select each individual sample for weighing in directly via the identification names. This is especially easy if the identification names are in the form of bar codes and you can use the LC-BCR bar-code reader.

- The procedure for entering the identification name of each sample is described in section 4.3.
- Weight values can also be determined automatically, see section 4.1.1.

### 3.1.3 Initial weight without tare container

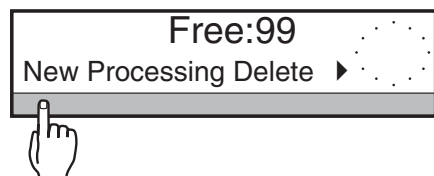

→ Press SmartBar under "New".

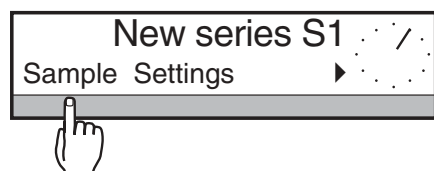

The next free series number is shown in the top line of the display and with the METTLER DeltaTrac.

→ Press SmartBar under "Sample".

The display of the top line switches to the weight display, the bottom line shows the series No., the sample No. and a text as user guidance which shows you the next step, e.g. "->Weigh-in".

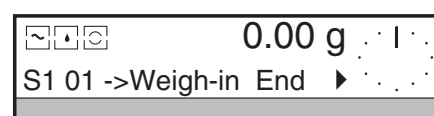

→ Load first sample, the prompt "Save\_Weight" then appears.

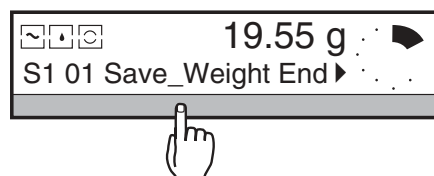

→ Use the SmartBar to save the weight, the prompt "->Unload" then appears.

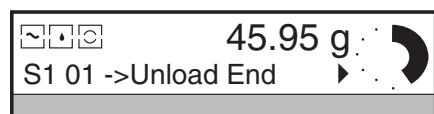

→ Remove sample from balance.

The balance is then set to zero, the sample number is incremented by 1 and the prompt "->Weigh-in" reappears.

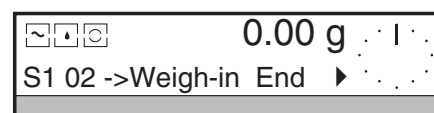

→ Load next sample etc.

•  
•  
•

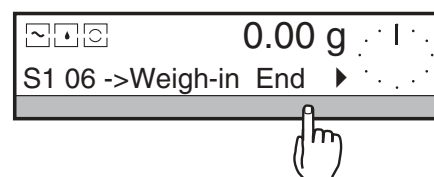

When all initial sample weights of the series have been determined:

→ Press SmartBar under "End".

The top line shows the inquiry "Close S1?" (S1 = series 1).

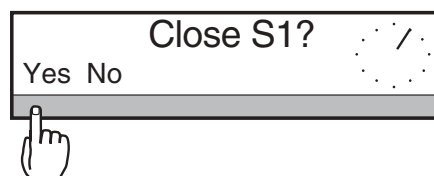

→ With "Yes" you end the first series and switch to simple weighing. With "No" you return to the last display under "Sample".

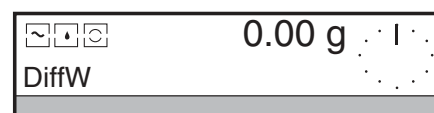

----- SAMPLE -----		
Series Number		1
1	NI	154.29 g
2	NI	152.51 g
3	NI	152.24 g
Signature:		
.....		
----- END -----		

### Printout

In the factory setting each weight value is printed out automatically with the sample number and labeled as a net initial weight (NI).

If you set the header printout in the menu (see section 6.4 of the operating instructions for the PR/SR balances), you can print out additional information, e.g. the balance identification.

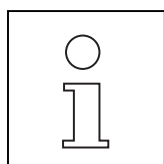

- If you do not have sufficient free storage space available for the new series or have already defined 9 series, the message "Memory full" appears. In such a case, first delete a completed series, see section 3.3.
- The series identification (LotID) is always available in differential weighing, irrespective of the settings in the menu.
- If you provide your series and samples with identification names, you can later call up the series or sample directly using its name.  
This is especially easy if the identification names are in the form of bar codes and you can use the LC-BCR bar-code reader.
- The procedure for entering the identification name for each sample is described in section 4.3.
- Weight values can also be determined automatically, see section 4.1.1.



### 3.2 Determining the back weight and difference

After treatment of the sample you reweigh it (= back weighing) to determine the weight difference. The individual samples can be back weighed in any order, see section 4.5. Further, not all samples of the series must be back weighed directly in succession. This can also be done later in a second run. A sample can be back weighed up to 99 times. After the 2nd back weighing, an index, e.g. [2] appears in the display and on the printout. However, the result always refers to the first initial weighing.

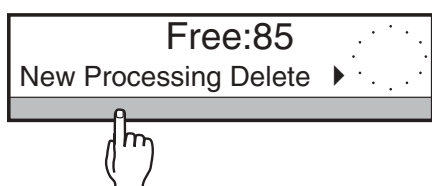

→ Press SmartBar under "Processing".

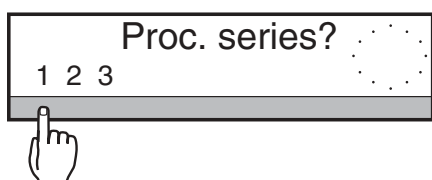

→ Select the desired series using the SmartBar.

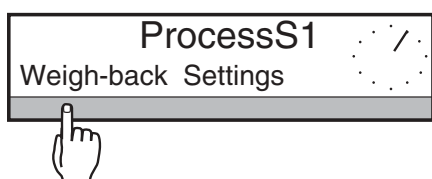

→ Press SmartBar under "Weigh-back".  
The display of the top line switches to the weight display, the bottom line shows the series No., sample No. and the prompt "→Load\_Sample".

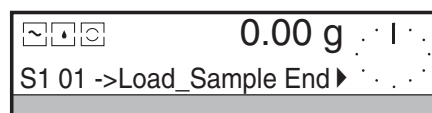

→ Perform the further steps in accordance with the user guidance until the step "→Unload".

•  
•  
•

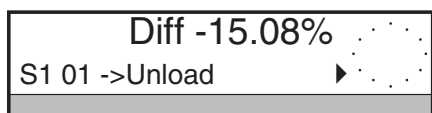

→ Remove sample from balance.  
The balance is then set to zero, the sample counter is incremented by 1 and the prompt "→Load\_Sample" reappears.

→ Load next sample etc.

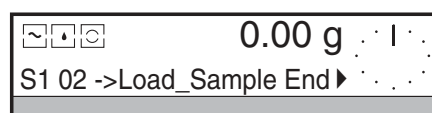

When all back weighings of the series have been performed, the message "Last sample" appears briefly followed by the inquiry "Close S1?" (S1 = series 1).

•  
•  
•

If you do not wish to back weigh some samples until later, press SmartBar under "End" to end the back weighing prematurely.

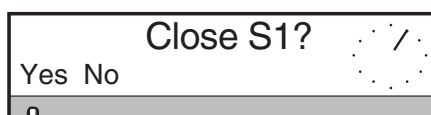

→ With "Yes" you end the series and switch to simple weighing. With "No" you return to the last display under "Weigh-back".

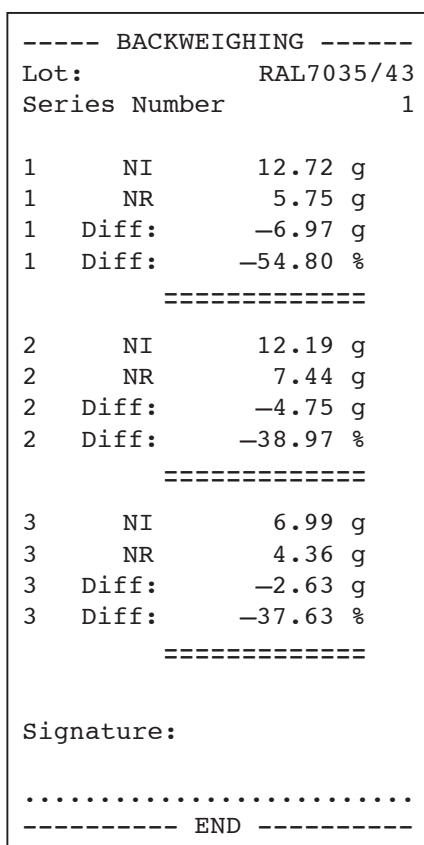
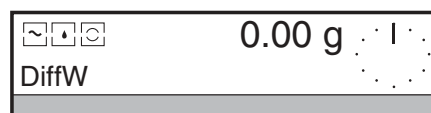

### Printout

In the factory setting, each weight value is automatically printed out – with sample number and labeled as a net back weight (NR). Tare values (T) are printed out only if such a printout has been set (see section 4.1.2).

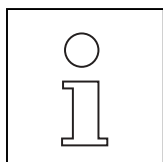

- If you work with identifications of the samples, you can also call up each sample directly using its identification name. This is especially easy if the identification names are in the form of bar codes and you can use the LC-BCR bar-code reader.
- Weight values can also be determined automatically, see section 4.1.1.

### 3.3 Deleting a series

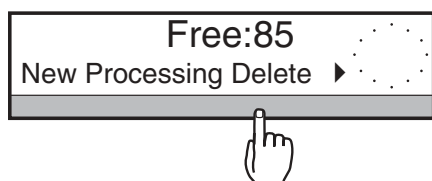

→ Press SmartBar under "Delete".  
The top line of the display shows "Del. series?", the bottom line shows all existing series.

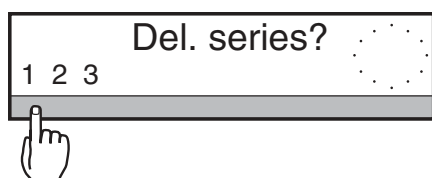

→ Use the SmartBar to select the series you wish to delete. The top line of the display shows the inquiry "Delete S1?" (S1 = series 1).

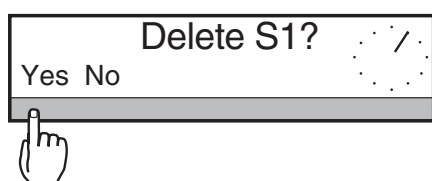

→ With "Yes" you delete the series and switch to the selection under "DiffW". The number of free storage locations (shown by "Free:xx") is increased accordingly.  
With "No" you move to the selection under "DiffW", the number of free locations remains unchanged.



### 3.4 Exiting differential weighing / Switching to weighing

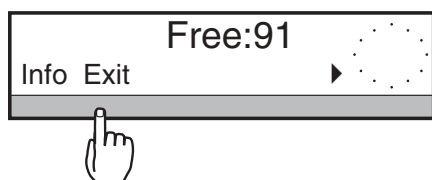

Whenever you answer "Close S?" with "YES", the balance automatically switches to simple weighing.  
If you wish to switch to simple weighing before the end of a series, proceed as follows:

→ Press SmartBar under "Exit".  
The balance switches to the weight display.  
The balance then behaves as in simple weighing as described in the operating instructions for PR/SR balances.



## 4 Additional functions

### 4.1 Setting the weight transfer and printout

For each series you wish to define or process further, you can always select the type of weight transfer and the data to be printed out. Further, you can decide whether the printout should be on-line or not take place until the end of a series. In this case, for each new series the settings of the series you last defined are adopted automatically.

- Press SmartBar under "New" or if you wish to change the current setting: Press SmartBar under "Processing" and select the desired series.
- Press SmartBar under "Settings". The top line of the display shows "Settings S1". (S1 = series 1), in the bottom line you have the following selection:
  - "WeightEntry" Here you define how the weighing result should be transferred, see section 4.1.1.
  - "Printout" Here you define which data should be printed out, see section 4.1.2.
  - "PrintTime" Here you select the time when the results should be printed out, see section 4.1.3.

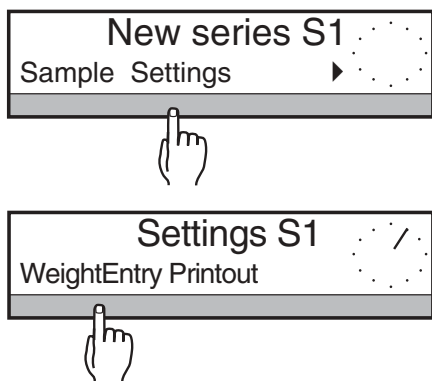

#### 4.1.1 Setting type of weight transfer

- Press SmartBar under "WeightEntry". The bottom line shows the following selection:
  - "Manual" Each weight transfer must be confirmed with the SmartBar when the appropriate prompt appears.
  - "Auto" The weight is transferred automatically on stability of the weight display, i.e. during the processing of the individual samples of the series you do not need to press a key, the appropriate prompts do not appear.

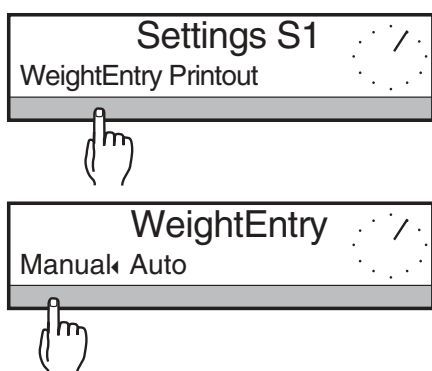

- Mark the desired setting with the SmartBar and confirm with ↵.

### 4.1.2 Setting print data

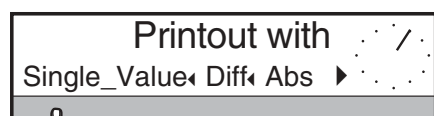

→ Press SmartBar under "Printout". The bottom line shows the following selection:

"Single\_Value" If "Single\_Value" is not marked, only the back weighing results will be recorded in the selected manner, i.e. as difference or absolute values (residual weight).

If "Single\_Value" is marked, the weight values will be recorded individually for every sample (factory setting).

Further, the following additional data can be printed out:

"SID" Sample names for each sample. The prompt for entry of the sample identification then appears automatically before every sample (see also section 4.3).

"Date" Date of weighing for each of the values tare, initial weight, back weight.

"Time" Time of weighing for each of the values tare, initial weight, back weight

"Tare" Printout with tare value if work performed with containers.

The selection of these additional data appears when the SmartBar is pressed under the **un-marked** key word "Single\_Value".

"Diff" Difference between back weight and initial weight (factory setting).

The difference between the back weight and the initial weight is displayed and printed out in % of the initial weight.

The printout also shows the difference in the selected weighing unit.

"Abs" The absolute value of the back weight (residual value) is displayed and printed out in % of the initial weight.

The printout also shows the back weight value (residual value) in the selected weighing unit.

"Statistics" Statistics over the back weighing values in percent of the initial weight. The following values are calculated and recorded.

Number of values, mean value and standard deviation for the type of the selected result (difference or absolute value (residual value) in % of the initial weight).

2	Diff:	-50.79 g
2	Diff:	-33.18 %
=====		

2	NR	102.44 g
2	NR	67.00 %
=====		

Statistics Backwgh.		
n		2
x	diff	-13.129 %
s		0.076 %
=====		



→ Mark the desired setting with the SmartBar and confirm with ↵.

### 4.1.3 Selecting print time

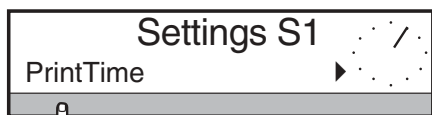

→ Press SmartBar under "PrintTime". The bottom line shows the following selection:



"Online" Printout after every weight transfer (factory setting).

"Offline" Printout only on completion of a workstep for a series.

In this case, "WithPrintout " also appears in the selection in addition to "Yes" and "No" with the inquiry "Close S1?".



→ Mark the desired setting with the SmartBar and confirm with ↵.



→ Press the ↵ key again to return to the initial status under "New" or "Processing".

## 4.2 Recalling results and printing out – "Info"

To ensure you are informed at all times on the status of your series, you can recall or print out all weighing results using the balance display.

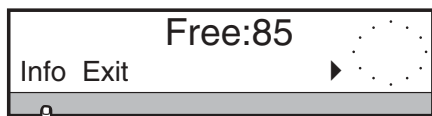

→ Press SmartBar under "Info". The top line of the display shows "Info series?", the bottom line all existing series.

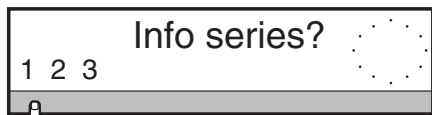

→ Select the desired series with the SmartBar.

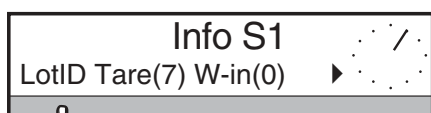

After selection of the series, you can call up the following information by pressing the SmartBar under the relevant key word:

```

- DIFFERENTIAL WEIGHING -
Info
Series Number          3

ID:                    1065
25.01.96              09:18
1      NI      233.095 g
25.01.96              09:41
1      NR      236.910 g
1      Diff:    3.815 g
1      Diff:    1.64 %
=====

ID:                    1066
25.01.96              09:18
2      NI      231.874 g
25.01.96              09:41
2      NR      234.618 g
2      Diff:    2.744 g
2      Diff:    1.18 %
=====

ID:                    1067
25.01.96              09:18
    
```

**LotID** Display series identification of the selected series.

At this point you can also modify the series identification.

**Tare (xx)** Display all existing tare values. "xx" represents the number of stored values.

The bottom line shows the associated sample identification with SID (if entered).

With "Next" you move to the tare weight value of the next sample.

**W-in (xx)** Display all existing initial weights.

The bottom line shows the associated sample identification with SID (if entered).

With "Next" you move to the initial weight value of the next sample.

**W-back (xx)** Display all existing back weights.

The bottom line shows the associated sample identification with SID (if entered).

With "Next" you move to the back weight value of the next sample.

**Print** Print all stored data in accordance with the setting under "Settings -> Single\_Value -> Printout".

```

5      NI      232.147 g
25.01.96              09:43
5      NR      236.857 g
5      Diff:    4.710 g
5      Diff:    2.03 %
=====

Statistics Backwgh.
n                    5
x      diff          1.520 %
s                    0.354 %
=====

Signature:
.....
----- END -----
    
```

**Example**

The printout opposite was generated with the following settings: Individual values with sampleID, date and time, but without tare values; printout of difference and statistics; printout on completion of the series.

### 4.3 Working with identification names

With the entry of "LotID", the Differential weighing application software always offers a means to identify the series.

In addition, you can activate the alphanumeric sample identification "SID" under "Settings →Single\_Value".

When weighing in, "SampleID" then appears in the bottom line. In this manner you can provide identify every individual sample with an alphanumeric identification.

If the identification names exist as bar codes, you can enter these directly with the LC-BCR bar-code reader from METTLER TOLEDO without pressing the SmartBar, see section 4.4.

#### Entering sample identification

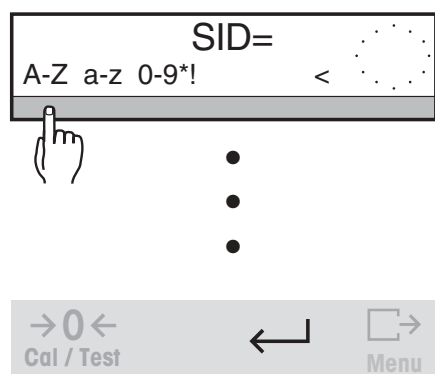

Before determination of the tare weight, the input prompt "SID=" automatically appears in the top line of the display.

- Enter sample identification automatically and confirm with the ↵ key or read in directly using the bar-code reader. The weight can then be determined.
- If you do not wish to enter the sample identification until the weighing-in stage, cancel the input prompt with the →T← key. The input prompt then appears automatically in weighing in.

You can also enter the sample identification earlier. Proceed as follows:

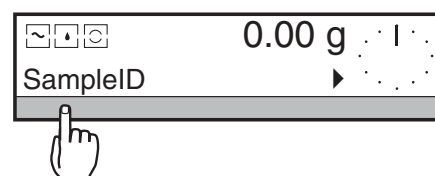

- Press SmartBar under "SampleID". The top line of the display shows the input prompt "SID=".
- Enter sample identification alphanumerically and confirm with the ↵ key or read in directly with the bar-code reader.



### 4.4 Working with the LC-BCR bar-code reader

If your identification names exist as bar codes, you can read in the series and sample identification directly with the LC-BCR bar-code reader.

#### Your benefits

- You do not need to press the SmartBar for the alphanumeric entry,
- you can enter the identification names at any time, e.g. even before you place the sample on the balance,
- you can select series and sample simply using the bar code.

#### Example: Back weighing of sample 05 from series 1

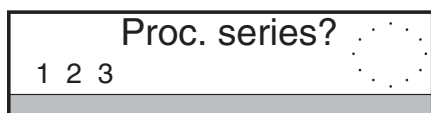

→ Read in series number with the bar-code reader.

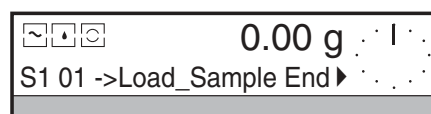

After selection of "Weigh-back", the first sample appears automatically.

→ Read in sample identification of sample 05 with the bar-code reader, sample 05 can now be back weighed.

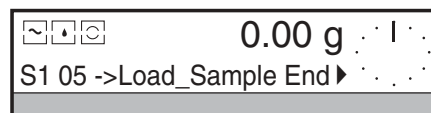

### 4.5 Arbitrary order of the samples

When a new series is defined, the sample numbers can be assigned completely arbitrarily, numbers can even be left out. As long as you have not closed the series, you can recall and determine the initial weight of a sample number already allocated. The old weight value of the sample will be overwritten in such a case.

When a series is defined or processed, the bottom line of the display shows the current series, e.g. "S2". This is followed by the sample number, e.g. "07". The Differential weighing application software processes the samples in ascending order as standard.

If you do not wish to process the sample number suggested automatically (e.g. 08) as the next sample, but sample 10, proceed as follows:

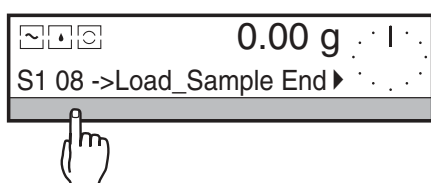

→ Press SmartBar under the sample number suggested automatically.  
The top line shows the current sample counter, e.g. "SampleNo=8".

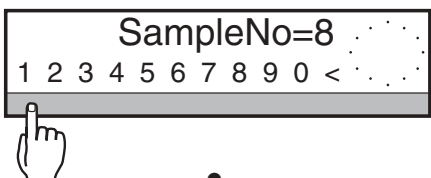

→ Enter number of desired sample, e.g. "10" and confirm with ↵. The display switches to the weight display and you can now process sample 10.

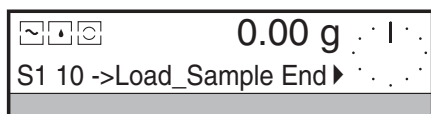

#### Selecting sample using sample identification when processing the series

→ Read in sample identification with the bar-code reader.  
The bottom line automatically shows the associated sample number.

In this manner you can conveniently process your samples in any order.

### 4.6 Marking imperfect samples

If the back weighing shows you there is something wrong with your sample, you have the possibility to mark this in the series as "imperfect". You can then no longer back weigh this sample by further back weighings, the message "No value" appears.

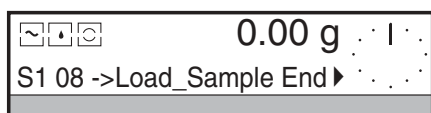
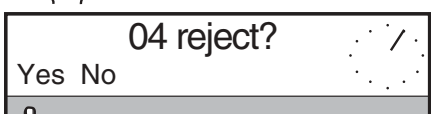
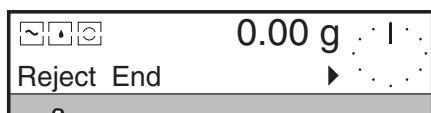

- Select sample number of the imperfect sample.
- Press SmartBar under "Reject" if the sample in question is imperfect.  
The top line of the display shows the inquiry "Reject 04?" (04 = sample number).
- With "Yes" mark the sample as imperfect and return to the last display under "Weigh-back", the sample number is incremented by 1.  
With "No" the sample is not marked. You return to the last display under "Weigh-back".

```

----- BACKWEIGHING -----
Series Number          1
1      NI      153.89 g
1      NR      102.99 g
1      NR      66.92 %
=====
2      NI      154.02 g
2      **      rejected
=====
3      NI      153.06 g
3      NR      102.27 g
3      NR      66.82 %
=====
      •
      •
      •
    
```

#### Printout

While the printout shows the sample, the back weighing value is marked by "\* rejected".

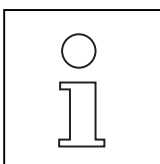

On call up of a back weighing value of a sample marked as "rejected", "-9999.99 g" appears in the display.

## 5 The menu

When the application cassette is changed, the menu of your balance also changes.

Differences from the menu of the standard balance software:

- Under the menu item "APPL", only the two possibilities "None" (simple weighing) and "DiffWeigh" (differential weighing) can be selected.
- The Differential weighing application software is available in 5 languages. The menu item "LANGUAGE" offers the selection "English Deutsch Français Español Italiano".
- The setting of LotID and SampleID under "SYSTEM ->Printout ->Header" refers only to the "None" application.

However, for the "DiffWeigh" application the printout of the balance ID, the date and the time can be set here. The printout of the sampleID at the user control level under DiffW can be individually defined for each processing step of a series.

All settings for differential weighing can be made at the user control level.

**The menu of the Differential weighing application software**

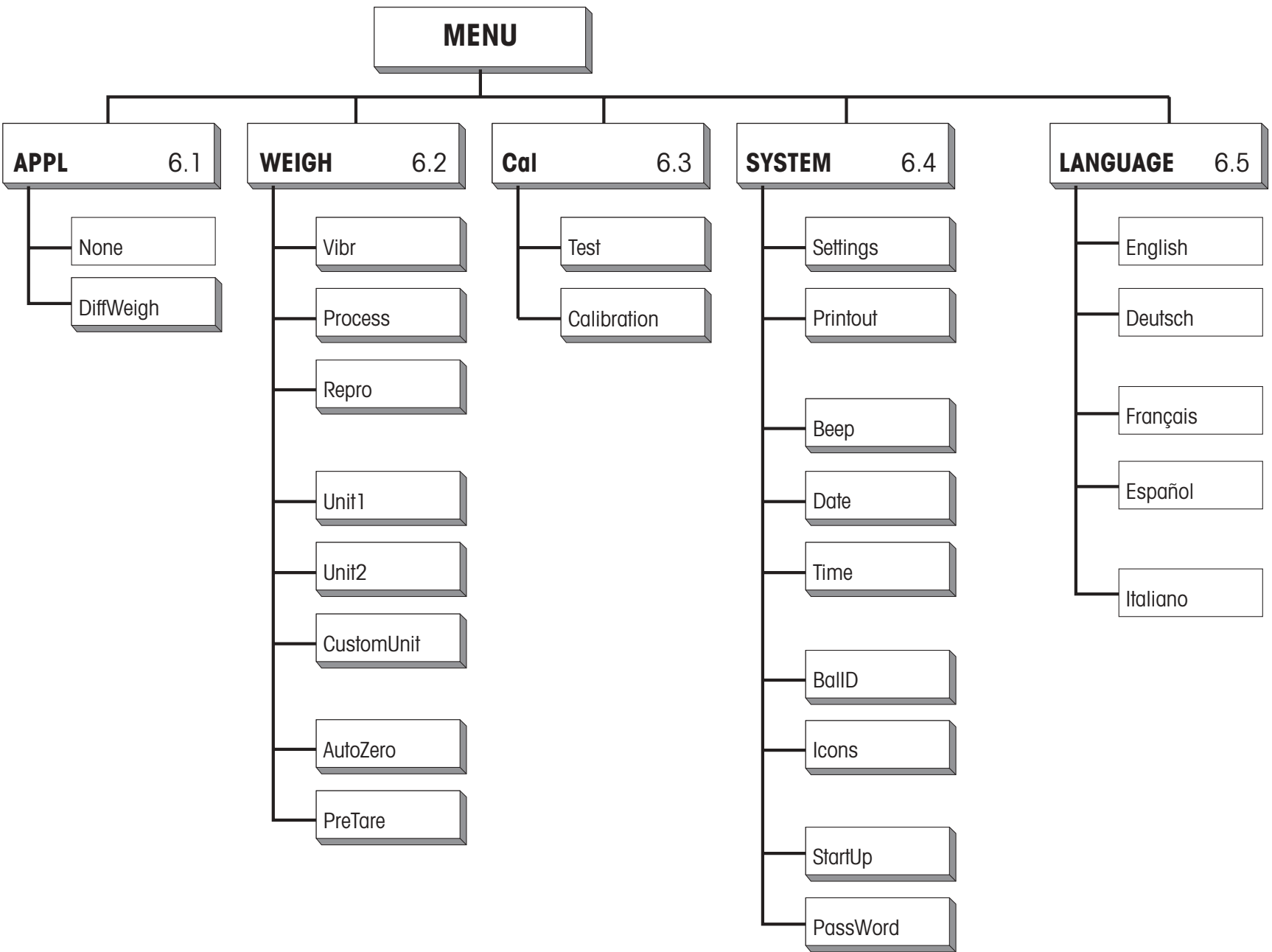

**Overview of the settings possibilities in differential weighing**

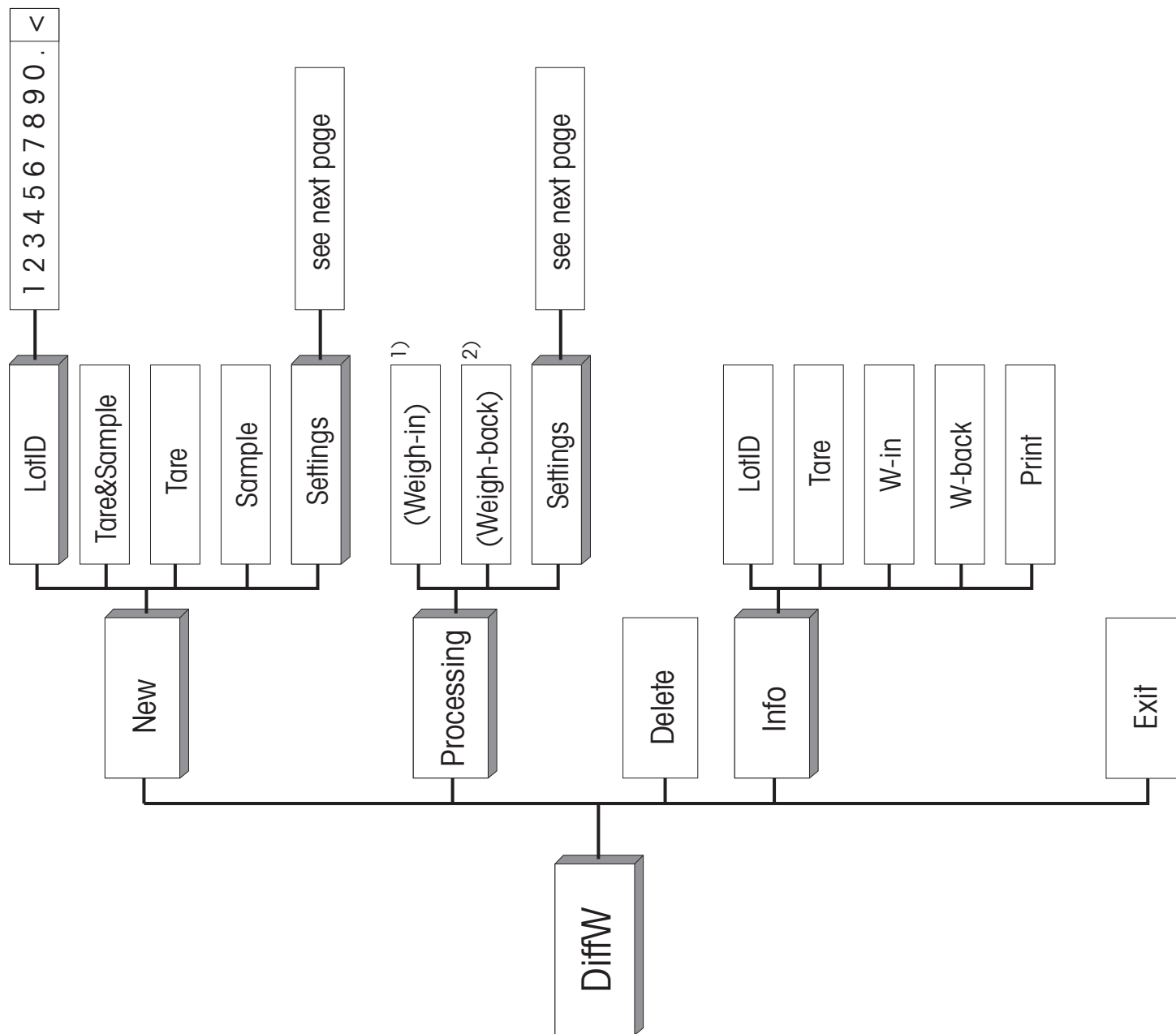

- 1) Weigh-in appears only in determination of tare and initial weight in two separate worksteps when tare values have been determined, but not yet all initial weights.
- 2) In determination of tare and initial weight in two separate worksteps, weigh-back does not appear until at least one initial weight of the series has been determined.

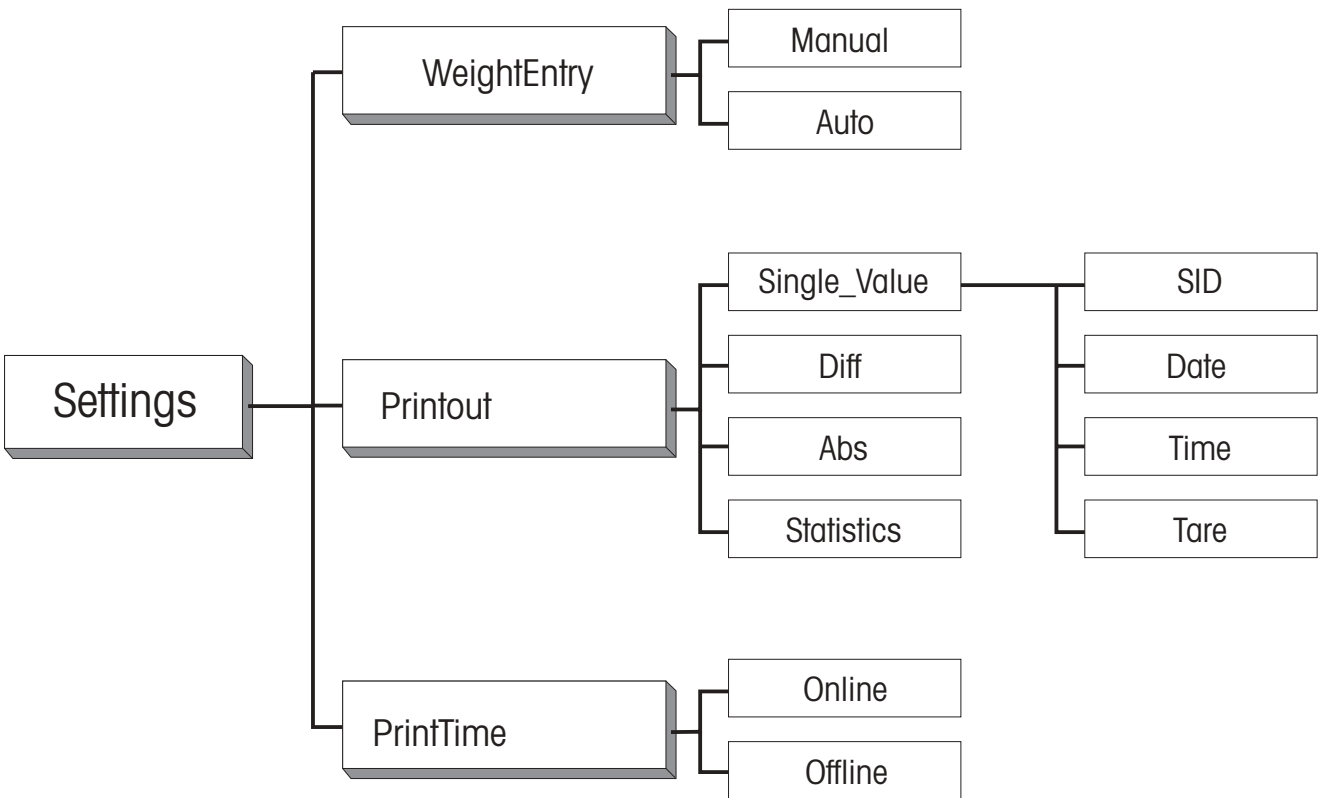

## 6 Communication with the computer, technical data

### 6.1 Transferring the weighing results via the LocalCAN universal interface

Each PR/SR balance is fitted with the LocalCAN universal interface as standard. With an appropriate cable (see section 7.3 of the operating instructions for PR/SR balances), you can attach your computer to the PR/SR balance via an RS232C interface.

PR/SR balances support the standard command set "Standard Interface Command Set (MT-SICS)". The reference manual (705184) that you received with the LC-RS or LC-CL cable describes the function of these commands in an easily surveyed manner.

The commands of MT-SICS level 0 and 1 and level 2 R standard also apply when the Differential weighing application software is used.

However, instead of the commands under MT-SICS level 3 of the standard R software, with the Differential weighing software an application-specific command is available.

This allows the transfer of the determined weight values tare, initial weight and back weight for each sample within the selected series to the attached computer.

#### Request active series

Command	<b>BW80</b>	Request active series
Response	<b>BW80 A x1 x2 x3 x4 x5 x6 x7 x8 x9</b>	
		xy = 0 Series y not available
		xy = 1 Weighing values for series y available
	<b>BW80 I</b>	The command can not be executed at present, the balance is currently executing a function, e.g. taring or is in the menu status.

#### Example

Command	<b>BW80</b>	
Response	<b>BW80 A 100100101</b>	Series 1, series 4, series 7 and series 9 available

#### Transferring values of a series

Command	<b>BW80 y</b>	Transfer values of series y, y = 1 ... 9
Responses	<b>BW80 A y 1 Tare1 Unit Sample1 Unit Backweighing1 Unit</b>	
	<b>BW80 A y 2 Tare2 Unit Sample2 Unit Backweighing2 Unit</b>	
	<b>BW80 A y 3 Tare3 Unit Sample3 Unit Backweighing3 Unit</b>	
	...	





## 7 Messages in the display

During operation of the balance a message or an unusual display may appear briefly in the top line of the display. There are two different types of messages: Information (type "I") or error message if operating errors occur (type "F").

Supplementing the messages described in section 8.3 of the operating instructions for the PR/SR balances, the following messages can appear with the Differential weighing application software.

Message	Type	Meaning	Corrective action, comments
Printing	I	<ul style="list-style-type: none"> <li>Weighing results being transferred to printer</li> </ul>	
Input ok	I	<ul style="list-style-type: none"> <li>The identification name of the series or sample (read in using bar-code reader) have been found, jump to this series/sample</li> </ul>	
No weigh-in	F	<ul style="list-style-type: none"> <li>No initial weight yet under the inputted sample number or sample identification</li> </ul>	→ First weigh in sample under "Processing"
No value	F	<ul style="list-style-type: none"> <li>No value found under the selected sample number or inputted sample identification, sample rejected at backweighing respectively</li> </ul>	→ Enter correct sample number or identification
Last sample	I	<ul style="list-style-type: none"> <li>Weigh in or back weigh last sample of the series</li> </ul>	
Memory full	F	<ul style="list-style-type: none"> <li>9 series or 99 samples already exist, no further samples can be stored and no further series defined</li> </ul>	→ Delete a series whose results are no longer needed
Value exists	I	<ul style="list-style-type: none"> <li>A tare value or initial weight value already exists under the inputted sample number or sample identification. This will be overwritten if a new value is saved</li> </ul>	
Illegal value	F	<ul style="list-style-type: none"> <li>An attempt has been made to save a negative tare value or an initial weight value less than a display increment</li> </ul>	→ Zero balance before loading container → Increase initial weight



**To protect your METTLER TOLEDO product's future:  
METTLER TOLEDO service assures the quality, measuring  
accuracy and preservation of value of all METTLER TOLEDO  
products for years to come.  
Please send for full details about our attractive terms of  
service.  
Thank you.**



**\*P11780133\***

Subject to technical changes.  
Printed on 100 % chlorine-free paper.  
For the sake of our environment.